

CHORUS LINE 8™
user manual

©2020 ELATION PROFESSIONAL all rights reserved. Information, specifications, diagrams, images, and instructions herein are subject to change without notice. ELATION PROFESSIONAL logo and identifying product names and numbers herein are trademarks of ELATION PROFESSIONAL. Copyright protection claimed includes all forms and matters of copyrightable materials and information now allowed by statutory or judicial law or hereinafter granted. Product names used in this document may be trademarks or registered trademarks of their respective companies and are hereby acknowledged. All non-ELATION brands and product names are trademarks or registered trademarks of their respective companies.

ELATION PROFESSIONAL and all affiliated companies hereby disclaim any and all liabilities for property, equipment, building, and electrical damages, injuries to any persons, and direct or indirect economic loss associated with the use or reliance of any information contained within this document, and/or as a result of the improper, unsafe, insufficient and negligent assembly, installation, rigging, and operation of this product.

Elation Professional USA | 6122 S. Eastern Ave. | Los Angeles, CA. 90040
 323-582-3322 | 323-832-9142 fax | www.elationlighting.com | info@elationlighting.com

Elation Professional B.V. | Junostraat 2 | 6468 EW Kerkrade, The Netherlands
 +31 45 546 85 66 | +31 45 546 85 96 fax | www.elationlighting.eu | info@elationlighting.eu

Elation Professional Mexico | AV Santa Ana 30 | Parque Industrial Lerma, Lerma, Mexico 52000
 +52 (728) 282-7070

DOCUMENT VERSION



Due to additional product features and/or enhancements, an updated version of this document may be available online. Please scan the QR Code with your mobile device or visit www.elationlighting.com for the latest revision/update of this manual before installation and/or programming.

Date	Document Version	Software Version ≥	DMX Channel Modes	Notes
10/19/17	1	1.02	16 / 18 / 46	Initial release.
01/26/18	1.2	1.03	NO CHANGE	Added sACN, Pixel Flip, Art-Net/Kling-Net dual control.
07/25/18	1.4	1.08	NO CHANGE	Updated manual format.
06/25/20	1.6	N/C	NO CHANGE	Updated thermal
10/16/20	1.8	N/C	NO CHANGE	Updated specifications
05/24/21	2.0	1.09	NO CHANGE	Updated Software

CONTENTS

General Information	4
Limited Warranty (USA Only)	5
Safety Guidelines	6
Maintenance Guidelines	8
Fixture Overview	9
Installation Guidelines	10
System Menu	13
DMX Channel Functions and Values	15
Color Macro Chart	21
Pixel Control	22
Specifications	23
Optional Accessories	25

GENERAL INFORMATION

INTRODUCTION

This fixture has been designed to perform reliably for years when the information in this manual are followed. Please read and understand all the instructions and guidelines carefully and thoroughly before operating this unit. This manual contains important information regarding safety, installation, use, and maintenance.

UNPACKING

Each fixture has been thoroughly tested and shipped in perfect operating condition. Carefully check the outer shipping carton for signs of any damage that may have occurred during shipping. If the outer carton appears to be damaged, carefully inspect the fixture for damage and be sure all included accessories have arrived intact. In the event damage has been found and/or parts are missing, please contact our customer support team for further instructions. Please do NOT return this fixture to your dealer without first contacting customer support at the number listed below. Please do NOT discard the outer shipping carton in the trash. Please recycle whenever possible.

CUSTOMER SUPPORT

Elation Professional provides a customer support line to provide set up help and answer any set up or operation questions. You may also visit us on the web at www.elationlighting.com for any comments or suggestions. For service related issue please contact Elation Professional.

ELATION SERVICE USA - Monday - Friday 8:00am to 5:00pm PST

Voice: 323-582-3322

Fax: 323-832-9142

E-mail: support@elationlighting.com

ELATION SERVICE EUROPE - Monday - Friday 08:30 to 17:00 CET

Voice: +31 45 546 85 30

Fax: +31 45 546 85 96

E-mail: support@elationlighting.eu

WARRANTY REGISTRATION / RETURNS

Please register online: <http://www.elationlighting.com/Login.aspx> to validate your purchase. All returned service items whether under warranty or not, must be freight pre-paid and accompany a return authorization (R.A.) number. The R.A. number must be clearly written on the outside of the return package. A brief description of the problem as well as the R.A. number must also be written down on a piece of paper and included in the shipping container. If the unit is under warranty, you must provide a copy of your proof of purchase invoice. Items returned without a R.A. number clearly marked on the outside of the package will be refused and returned at customer's expense. You may obtain a R.A. number by contacting customer support.

LIMITED WARRANTY (USA ONLY)

- A. Elation Professional hereby warrants, to the original purchaser, Elation Professional products to be free of manufacturing defects in material and workmanship for a period of two years (730 days), and Elation Professional product rechargeable batteries to be free of manufacturing defects in material and workmanship for a period of six months (180 days), from the original date of purchase. This warranty excludes discharge lamps and all product accessories. This warranty shall be valid only if the product is purchased within the United States of America, including possessions and territories. It is the owner's responsibility to establish the date and place of purchase by acceptable evidence, at the time service is sought.
- B. For warranty service, send the product only to the Elation Professional factory. All shipping charges must be pre-paid. If the requested repairs or service (including parts replacement) are within the terms of this warranty, Elation Professional will pay return shipping charges only to a designated point within the United States. If any product is sent, it must be shipped in its original package and packaging material. No accessories should be shipped with the product. If any accessories are shipped with the product, Elation Professional shall have no liability whatsoever for loss and/or or damage to any such accessories, nor for the safe return thereof.
- C. This warranty is void if the product serial number and/or labels are altered or removed; if the product is modified in any manner which Elation Professional concludes, after inspection, affects the reliability of the product; if the product has been repaired or serviced by anyone other than the Elation Professional factory unless prior written authorization was issued to purchaser by Elation Professional; if the product is damaged because not properly maintained as set forth in the product instructions, guidelines and/or user manual.
- D. This is not a service contract, and this warranty does not include any maintenance, cleaning, or periodic check-up. During the periods as specified above, Elation Professional will replace defective parts at its expense, and will absorb all expenses for warranty service and repair labor by reason of defects in material or workmanship. The sole responsibility of Elation Professional under this warranty shall be limited to the repair of the product, or replacement thereof, including parts, at the sole discretion of Elation Professional. All products covered by this warranty were manufactured after January 1, 1990, and bare identifying marks to that effect.
- E. Elation Professional reserves the right to make changes in design and/or performance improvements upon its products without any obligation to include these changes in any products theretofore manufactured.
- F. No warranty, whether expressed or implied, is given or made with respect to any accessory supplied with the products described above. Except to the extent prohibited by applicable law, all implied warranties made by Elation Professional in connection with this product, including warranties of merchantability or fitness, are limited in duration to the warranty periods set forth above. And no warranties, whether expressed or implied, including warranties of merchantability or fitness, shall apply to this product after said periods have expired. The consumer's and/or dealer's sole remedy shall be such repair or replacement as is expressly provided above; and under no circumstances shall Elation Professional be liable for any loss and/or damage, direct and/or consequential, arising out of the use of, and/or the inability to use, this product.
- G. This warranty is the only written warranty applicable to Elation Professional products and supersedes all prior warranties and written descriptions of warranty terms and conditions heretofore published.

SAFETY GUIDELINES

This fixture is a sophisticated piece of electronic equipment. To guarantee a smooth operation, it is important to follow all instructions and guidelines in this manual. Elation Professional is not responsible for injury and/or damages resulting from the misuse of this fixture due to the disregard of the information printed in this manual. Only qualified and/or certified personnel should perform installation of this fixture and only the original rigging parts (omega brackets) included with this fixture should be used for installation. Any modifications to the fixture and/or the included mounting hardware will void the original manufactures warranty and increase the risk of damage and/or personal injury.



PROTECTION CLASS 1 - FIXTURE MUST BE PROPERLY GROUNDED



**THERE ARE NO USER SERVICEABLE PARTS INSIDE THIS UNIT.
DO NOT ATTEMPT ANY REPAIRS YOURSELF; DOING SO WILL VOID YOUR
MANUFACTURES WARRANTY. DAMAGES RESULTING FROM
MODIFICATIONS TO THIS FIXTURE AND/OR THE DISREGARD OF SAFETY
INSTRUCTIONS AND GUIDELINES IN THIS MANUAL VOID THE
MANUFACTURES WARRANTY AND ARE NOT SUBJECT TO ANY
WARRANTY CLAIMS AND/OR REPAIRS.**



**DO NOT PLUG FIXTURE INTO A DIMMER PACK!
NEVER OPEN THIS FIXTURE WHILE IN USE!
UNPLUG POWER BEFORE SERVICING FIXTURE!
NEVER TOUCH FIXTURE DURING OPERATION, AS IT MAY BE HOT!
KEEP FLAMMABLE MATERIALS AWAY FROM FIXTURE!**



**NEVER LOOK DIRECTLY INTO THE LIGHT SOURCE!
RETINA INJURY RISK - MAY INDUCE BLINDNESS!
SENSITIVE PERSONS MAY SUFFER AN EPILEPTIC SHOCK!**



**INDOOR / DRY LOCATIONS USE ONLY!
DO NOT EXPOSE FIXTURE TO RAIN AND/OR MOISTURE!**

SAFETY GUIDELINES

DO NOT TOUCH the fixture housing during operation. Turn OFF the power and allow approximately 15 minutes for the fixture to cool down before serving.

DO NOT shake fixture, avoid brute force when installing and/or operating fixture.

DO NOT operate fixture if the power cord is frayed, crimped, damaged and/or if any of the power cord connectors are damaged and do not insert into the fixture securely with ease. **NEVER** force a power cord connector into the fixture. If the power cord or any of its connectors are damaged, replace it immediately with a new one of similar power rating.

DO NOT block any air ventilation slots.

All fan and air inlets must remain clean and never blocked.

Allow approx. 6" (15cm) between fixture and other devices or a wall for proper cooling.

When installing fixture in a suspended environment, always use mounting hardware that is no less than M10 x 25 mm, and always install fixture with an appropriately rated safety cable.

Always disconnect fixture from main power source before performing any type of service and/or cleaning procedure. Only handle the power cord by the plug end, never pull out the plug by tugging the wire portion of the cord.

During the initial operation of this fixture, a light smoke or smell may emit from the interior of the fixture. This is a normal process and is caused by excess paint in the interior of the casing burning off from the heat associated with the lamp and will decrease gradually over time.

Consistent operational breaks will ensure fixture will function properly for many years.

ONLY use the original packaging and materials to transport the fixture in for service.

MAINTENANCE GUIDELINES



DISCONNECT POWER BEFORE PERFORMING ANY MAINTENANCE!

CLEANING

Frequent cleaning is recommended to insure proper function, optimized light output, and an extended life. The frequency of cleaning depends on the environment in which the fixture operates: damp, smoky or particularly dirty environments can cause greater accumulation of dirt on the fixture's optics. Clean the external lens surface at least every 20 days with a soft cloth to avoid dirt/debris accumulation.

NEVER use alcohol, solvents, or ammonia-based cleaners.

MAINTENANCE

Regular inspections are recommended to insure proper function and extended life.

There are no user serviceable parts inside this fixture, please refer all other service issues to an authorized Elation service technician. Should you need any spare parts, please order genuine parts from your local Elation dealer.

Please refer to the following points during routine inspections:

A detailed review by an approved electrical engineer every three months, to make sure the circuit contacts are in good condition and prevent overheating.

Be sure all screws and fasteners are securely tightened at all times. Loose screws may fall out during normal operation resulting in damage or injury as larger parts could fall.

Check for any deformations on the housing, color lenses, rigging hardware and rigging points (ceiling, suspension, trussing). Deformations in the housing could allow for dust to enter into the fixture. Damaged rigging points or unsecured rigging could cause the fixture to fall and seriously injure a person(s).

Electric power supply cables must not show any damage, material fatigue or sediments. **NEVER** remove the ground prong from the power cable.

FIXTURE OVERVIEW

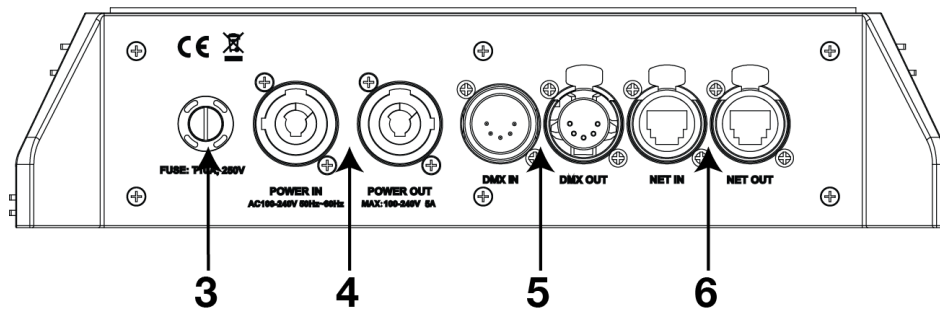
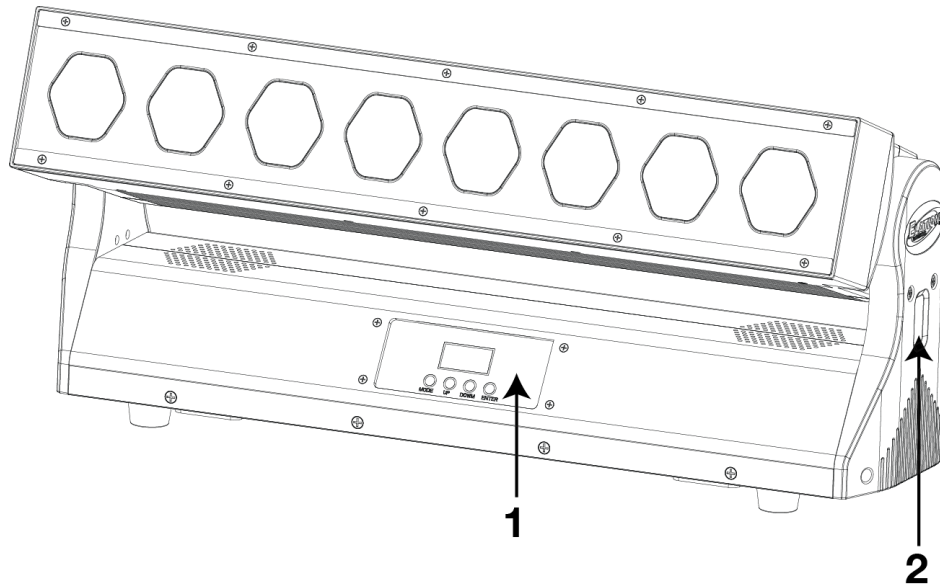

- 1. LCD Menu Display, MENU, UP, DOWN, ENTER Buttons
- 2. Tilt Lock
- 3. Fuse
- 4. Power IN/OUT
- 5. 5pin DMX IN/OUT
- 6. RJ45 Ethernet IN/OUT

INCLUDED ITEMS

- Replacement Lens Covers (x2)
- Omega Brackets (x2)
- Power Cable

INSTALLATION INSTRUCTIONS



FLAMMABLE MATERIAL WARNING

Keep fixture minimum 5.0 feet (1.5m) away from flammable materials and/or pyrotechnics.



ELECTRICAL CONNECTIONS

A qualified electrician should be used for all electrical connections and/or installations.



USE CAUTION WHEN POWER LINKING OTHER MODEL FIXTURES AS THE POWER CONSUMPTION OF OTHER MODEL FIXTURES MAY EXCEED THE MAX POWER OUTPUT ON THIS FIXTURE. CHECK SILK SCREEN FOR MAX AMPS.



DO NOT INSTALL THE FIXTURE IF YOU ARE NOT QUALIFIED TO DO SO!

Fixture **MUST** be installed following all local, national, and country commercial electrical and construction codes and regulations.

Before rigging/mounting a single fixture or multiple interconnected fixtures for custom matrix designs to any metal truss/structure or placing the fixture(s) on any surface, a professional equipment installer **MUST** be consulted to determine if the metal truss/structure or surface is properly certified to safely hold the combined weight of the fixture(s), clamps, cables, and accessories.

Fixture ambient operating temperature range is **15° to 113°F. (-15° to 45°C)**
Do not use the fixture under or above this temperature.

Fixture(s) should be installed in areas outside walking paths, seating areas, or away from areas where unauthorized personnel might reach the fixture by hand.

NEVER stand directly below the fixture(s) when rigging, removing or servicing.
Overhead fixture installation must always be secured with a secondary safety attachment, such as an appropriately rated safety cable that can hold 10 times the weight of the fixture.

Allow approximately 15 minutes for the fixture to cool down before serving.

INSTALLATION INSTRUCTIONS

CLAMP MOUNTING

The fixture can be placed on the flat surface or truss mounted. When mounting this fixture to truss be sure to secure (2) appropriately rated clamps (not included) to the **(2) Omega Brackets (included)** Be sure to attach the **Safety Cable (included)** to the fixture using the safety cable rigging points integrated into the bottom of the fixture. (See image below)

SAFETY CABLE RIGGING POINT

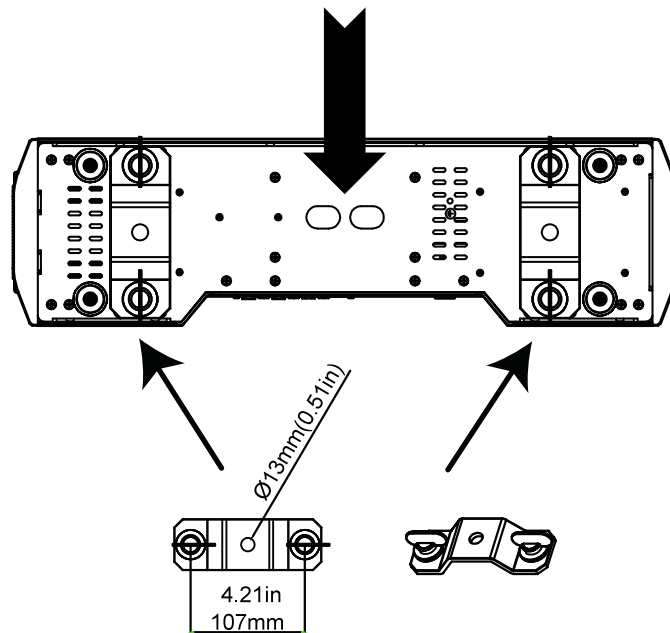

SAFETY CABLE

The fixture includes an integrated safety cable rigging point. (see image below)



ALWAYS ATTACH A SAFETY CABLE WHEN INSTALLING FIXTURE IN A SUSPENDED ENVIRONMENT TO ENSURE THE FIXTURE WILL NOT DROP IF THE CLAMP FAILS.

INSTALLATION INSTRUCTIONS

OVERHEAD RIGGING

Overhead rigging requires extensive experience, including amongst others calculating working load limits, installation material being used, and periodic safety inspection of all installation material and the fixture. If you lack these qualifications, do not attempt the installation yourself. Improper installation can result in bodily injury and property damage. Fixture is fully operational in the specific mounting positions illustrated below.

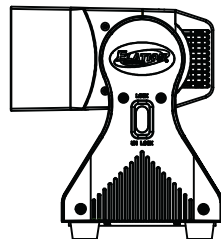
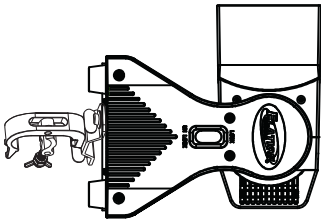
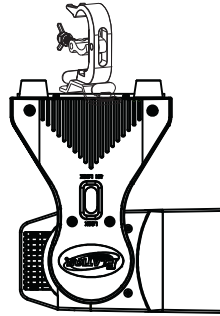

POWER LINKING



USE CAUTION WHEN POWER LINKING OTHER MODEL FIXTURES AS THE POWER CONSUMPTION OF OTHER MODEL FIXTURES MAY EXCEED THE MAX POWER OUTPUT ON THIS FIXTURE. CHECK SILK SCREEN FOR AMX AMPS.

KLING-NET / ART-NET CONNECTION

When connecting fixture to a network switch to control multiple devices, a **Gigabit Ethernet Switch** that supports **IGMP (Internet Group Management Protocol)** is required. Using a **Gigabit Ethernet Switch** that does not support **IGMP** can cause erratic behavior of all connected devices to the switch. Click link below for more information about IGMP.

https://en.wikipedia.org/wiki/Internet_Group_Management_Protocol

SYSTEM MENU

The fixture comes with an easy to navigate system menu. The control panel (see image below) located on the back of the fixture provides access to the main system menu and is where all necessary system adjustments are made to the fixture. During normal operation, pressing **MODE** button once will access the fixture's main menu. Once in the main menu you can navigate through the different functions and access the sub-menus with the **UP** and **DOWN** buttons. Once you reach a field that requires adjusting, press the **ENTER** button to activate that field and use the **UP** and **DOWN** buttons to adjust the field. Pressing the **ENTER** button once more will confirm your setting. You may exit the main menu at any time without making any adjustments by pressing the **MODE/ESC** button.

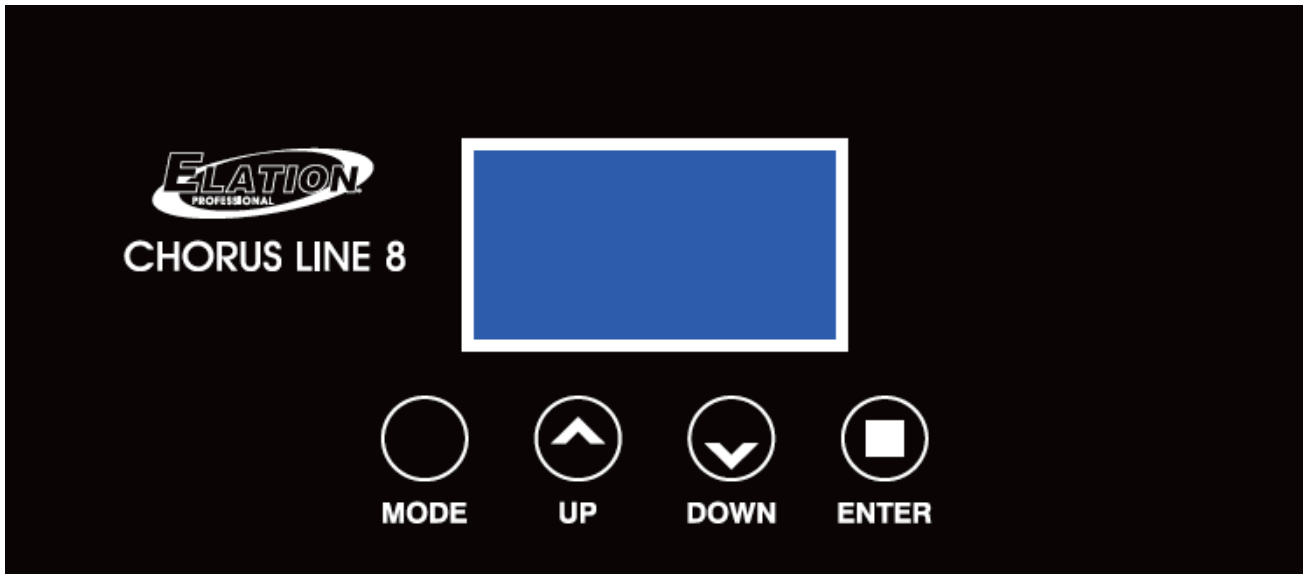

LCD CONTROL PANEL LOCKOUT

When the **Key Lock** menu is set to **ON**, the LCD display will turn OFF after 30 seconds and the (4) button Control Panel will be LOCKED. To unlock the (4) button LCD control panel, press and hold the **MODE** button.

INFORMATION DISPLAYED DURING INITIAL POWER ON

When the fixture is initially powered ON, the display shows the following information:



SYSTEM MENU

Supports Software Version: ≥ V1.09

Features are subject to change without any prior written notice.

MAIN MENU	SUB MENU	OPTIONS / VALUES (Default Settings in BOLD)		DESCRIPTION	
Address	Set DMX Address	001 ~ XXX		DMX Address Setting	
User Mode	Standard	18CH (16bit)		Set DMX Channel Mode	
	Basic	16CH (8bit)			
	Extend	46CH			
Function	Status	Lost DMX Mode	Hold / Auto / Blackout	Function If NO DMX Detected	
		Tilt Invert	ON / OFF	Tilt Reverse Movement	
		Feedback	ON /OFF	Movement Feedback	
		Move. Spd	Speed 1 ~ 4	Movement Mode Select	
		Stand By	OFF, 01M~99M, 15M	Stand By Mode	
	Fan. Set	Head Fan	Auto , High, Low	Fan Speed Set	
	Net ID	Password	Password=xxx		
		DeviceIP	xxx.xxx.xxx.xxx		
		Mark Addr	xxx.xxx.xxx.xxx		
		Universe	000-255		
	Protocol	ArtNet , SACN		Set Network Protocol	
	KlingNet	Enable / Disable		Enable KlingNet Protocol	
	Net	ON / OFF		Activate NET OUT Port.	
	LCD. Set	Backlight	02~60m 05m	LCD Backlight Shut Off Time	
		FlipDisplay	ON / OFF	Flip/Reverse LCD Display 180°	
		Key Lock	ON / OFF	Control Front Panel Buttons Key Lock	
		Flash	ON / OFF	Display flashes when NO DMX	
	Temp. C/F	Fahrenheit /Celsius		Temperature Switch Between F° / C°	
	Dim Curve	Standard , Stage, TV, Architectur, Theatre		Set Dimmer Curve Mode	
	Disp. Set	Chan. Value	TILT...		Value of each Channel Displayed
		Slave Set	Slave 1 , Slave 2, Slave 3		Set Slave Mode Preset
		Auto.Pro	Alone , Master		Set Auto Program Mode
	Gamma	2.0/2.2/2.4/2.8			
	Frequen	900 /1000/1100/1200/1300/1400/1500/2500/ 4000/5000/10k/15k/20k/25k			
	Pixel	Standard , Flip		Set Pixel Flip Mode	
	DFSE	ON / OFF		Restore Factory Settings	
	Information	Time. Info	Current	XXXX (Hours)	Fixture Run Time From Power ON
Total Time			XXXX (Hours)	Fixture Total Run Time	
Last Clear			XXXX (Hours)	Clear Fixture Last Run Time	
Password Clear/Clear-TO			Password= 050	Password to clear last fixture run time	
			Password= 060	Password to clear total run time	
		ON / OFF	Reset Fixture Last Run Time		
TempInfo		LED Temp.	XXX F° / C°	Temperature in Fixture Head	
Err. Info		Tilt.....		Display 10 Recent Error Messages	
ModellInfo	Chorus Line 8		Display Model Name		
Software Version	1U01 – 5U01	≥V1.09	Software Versions		
Test	Reset. M	All			
	Test. Ch	Tilt ...			
	ManCtrl	Tilt=XXXX :			
	Calibrat	Password Tilt, Red1, Green1, Blue1, White1...Red8, Green8, Blue8, White8, Zoom1, Zoom2		Password= 050	

DMX CHANNEL FUNCTIONS AND VALUES

Supports Software Versions: \geq V1.09				
Features are subject to change without any prior written notice. *Direction of effects and Pixel Control depends on orientation of the fixture head and Tilt/Pixel Flip settings.				
MODE / CHANNEL			VALUE	FUNCTION
BASIC CH: 16	STANDARD CH: 18	EXTEND CH: 46		
1	1	1	0-255	TILT Movement 8bit TILT Movement [127]
	2	2	0-255	Tilt Fine 16bit Fine Control of TILT Movement [127]
2	3		0-255	ALL Red 0 to 100% [255]
3	4		0-255	ALL Green 0 to 100% [255]
4	5		0-255	ALL Blue 0 to 100% [255]
5	6		0-255	ALL AMBR 0 to 100% [0]
		3	0-255	Red1 0 to 100% [255]
		4	0-255	Green1 0 to 100% [255]
		5	0-255	Blue1 0 to 100% [255]
		6	0-255	White1 0 to 100% [0]
		7	0-255	Red2 0 to 100% [255]
		8	0-255	Green2 0 to 100% [255]
		9	0-255	Blue2 0 to 100% [255]
		10	0-255	White2 0 to 100% [0]
		11	0-255	Red3 0 to 100% [255]
		12	0-255	Green3 0 to 100% [255]
		13	0-255	Blue3 0 to 100% [255]
		14	0-255	White3 0 to 100% [0]

MODE / CHANNEL			VALUE	FUNCTION
BASIC CH: 16	STANDARD CH: 18	EXTEND CH: 46		
		15	0-255	Red4 0 to 100% [255]
		16	0-255	Green4 0 to 100% [255]
		17	0-255	Blue4 0 to 100% [255]
		18	0-255	White4 0 to 100% [0]
		19	0-255	Red5 0 to 100% [255]
		20	0-255	Green5 0 to 100% [255]
		21	0-255	Blue5 0 to 100% [255]
		22	0-255	White5 0 to 100% [0]
		23	0-255	Red6 0 to 100% [255]
		24	0-255	Green6 0 to 100% [255]
		25	0-255	Blue6 0 to 100% [255]
		26	0-255	White6 0 to 100% [0]
		27	0-255	Red7 0 to 100% [255]
		28	0-255	Green7 0 to 100% [255]
		29	0-255	Blue7 0 to 100% [255]
		30	0-255	White7 0 to 100% [0]
		31	0-255	Red8 0 to 100% [255]
		32	0-255	Green8 0 to 100% [255]
		33	0-255	Blue8 0 to 100% [255]
		34	0-255	AMBR8 0 to 100% [0]
			0	Normal
			1-255	2,700K -7,000K [127]

MODE / CHANNEL			VALUE	FUNCTION
BASIC CH: 16	STANDARD CH: 18	EXTEND CH: 46		
	7	35		Color Temp
			8-255	2,700K -7,000K [127]
				COLOR PRESETS
			0	OFF [0]
			1-4	COLOR PRESET 01
			5-8	COLOR PRESET 02
			9-12	COLOR PRESET 03
			13-16	COLOR PRESET 04
			17-20	COLOR PRESET 05
			21-24	COLOR PRESET 06
			25-28	COLOR PRESET 07
			29-32	COLOR PRESET 08
			33-36	COLOR PRESET 09
			37-40	COLOR PRESET 10
			41-44	COLOR PRESET 11
			45-48	COLOR PRESET 12
			49-52	COLOR PRESET 13
			53-56	COLOR PRESET 14
6	8	36	57-60	COLOR PRESET 15
			61-64	COLOR PRESET 16
			65-68	COLOR PRESET 17
			69-72	COLOR PRESET 18
			73-76	COLOR PRESET 19
			77-80	COLOR PRESET 20
			81-84	COLOR PRESET 21
			85-88	COLOR PRESET 22
			89-92	COLOR PRESET 23
			93-96	COLOR PRESET 24
			97-100	COLOR PRESET 25
			101-104	COLOR PRESET 26
			105-108	COLOR PRESET 27
			109-112	COLOR PRESET 28
			113-116	COLOR PRESET 29
			117-120	COLOR PRESET 30
			121-124	COLOR PRESET 31
			125-128	COLOR PRESET 32

MODE / CHANNEL			VALUE	FUNCTION			
BASIC CH: 16	STANDARD CH: 18	EXTEND CH: 46					
6	8	36		Color Macros			
			129-132	COLOR PRESET 33			
			133-136	COLOR PRESET 34			
			137-140	COLOR PRESET 35			
			141-144	COLOR PRESET 36			
			145-148	COLOR PRESET 37			
			149-152	COLOR PRESET 38			
			153-156	COLOR PRESET 39			
			157-160	COLOR PRESET 40			
			161-164	COLOR PRESET 41			
			165-168	COLOR PRESET 42			
			169-172	COLOR PRESET 43			
			173-176	COLOR PRESET 44			
			177-180	COLOR PRESET 45			
			181-184	COLOR PRESET 46			
			185-188	COLOR PRESET 47			
			189-192	COLOR PRESET 48			
			193-196	COLOR PRESET 49			
			197-200	COLOR PRESET 50			
			201-204	COLOR PRESET 51			
			205-208	COLOR PRESET 52			
			209-212	COLOR PRESET 53			
			213-216	COLOR PRESET 54			
			217-220	COLOR PRESET 55			
			221-224	COLOR PRESET 56			
			225-228	COLOR PRESET 57			
			229-232	COLOR PRESET 58			
			233-236	COLOR PRESET 59			
			237-240	COLOR PRESET 60			
			241-244	COLOR PRESET 61			
			245-248	COLOR PRESET 62			
			249-252	COLOR PRESET 63			
			253-255	COLOR PRESET 64			
			7	9	37		SHUTTER / STROBE
						0-31	LED OFF
						32-63	LED ON
64-95	Strobe Effect SLOW to FAST						
96-127	LED ON						
128-159	Pulse Effect in Sequences						
160-191	LED ON						
192-223	Random Strobe Effect SLOW to FAST						
224-255	LED ON [255]						

MODE / CHANNEL			VALUE	FUNCTION
BASIC CH: 16	STANDARD CH: 18	EXTEND CH: 46		
8	10	38	0-255	DIMMER INTENSITY Dimmer 0 to 100% [0]
9	11	39	0-255	DIMMER INTENSITY FINE Dimmer FINE Adjustment [0]
10	12	40	0-255	ZOOM Zoom 0% (7 Degrees) to 100% (42 Degrees) [127]
11	13	41		PROGRAM MACROS NOTE: Color Must Be Selected To Engage Macros.
			0	LEDs ON [0]
			1-14	LEDs OFF
			15-30	PROGRAM MACRO 01
			31-46	PROGRAM MACRO 02
			47-62	PROGRAM MACRO 03
			63-78	PROGRAM MACRO 04
			79-94	PROGRAM MACRO 05
			95-110	PROGRAM MACRO 06
			111-126	PROGRAM MACRO 07
			127-142	PROGRAM MACRO 08
			143-158	PROGRAM MACRO 09
			159-174	PROGRAM MACRO 10
			175-190	PROGRAM MACRO 11
			191-206	PROGRAM MACRO 12
207-222	PROGRAM MACRO 13			
223-238	PROGRAM MACRO 14			
239-255	PROGRAM MACRO 15			
12	14	42	0-255	PROGRAM MACRO SPEED SLOW to FAST Speed [0]
13	15	43	0	PROGRAM MACRO FADE OFF [0]
			1-255	LESS to MORE FADE
14	16	44		DIMMING CURVE MODES
			0-20	STANDARD [20]
			21-40	STAGE
			41-60	TV
			61-80	ARCHITECTURAL
			81-100	THEATRE
101-255	Default to Unit Setting			
15	17	45		TILT MOVEMENT SPEED
			0-225	MAX to MIN SPEED [0]
			226-235	Blackout By Movement
			236-255	NO FUNCTION

MODE / CHANNEL			VALUE	FUNCTION
BASIC CH: 16	STANDARD CH: 18	EXTEND CH: 46		
16	18	46		LAMP ON/OFF, RESET, INTERNAL PROGRAMS
			0-79	Normal
			80-84	ALL Motor Reset
			85-99	NO FUNCTION
			100-119	Internal Program 1 (scene1~8)
			120-139	Internal Program 2 (scene9~16)
			140-159	Internal Program 3 (scene17~24)
			160-179	Internal Program 4 (scene25~32)
			180-199	Internal Program 5 (scene33~40)
			200-219	Internal Program 6 (scene41~48)
			220-239	Internal Program 7 (scene49~56)
			240-255	NO FUNCTION [255]

COLOR MACRO CHART

VALUES 1-4		DMX VALUES 53-56		DMX VALUES 105-108		DMX VALUES 157-160		DMX VALUES 209-212	
Red=	80	Red=	255	Red=	255	Red=	234	Red=	0
Green=	255	Green=	93	Green=	138	Green=	139	Green=	83
Blue=	234	Blue=	182	Blue=	186	Blue=	171	Blue=	115
W=	80	W=	93	W=	138	W=	0	W=	0
DMX VALUES 5-8		DMX VALUES 57-60		DMX VALUES 109-112		DMX VALUES 161-164		DMX VALUES 213-216	
Red=	80	Red=	255	Red=	255	Red=	224	Red=	0
Green=	255	Green=	96	Green=	147	Green=	5	Green=	97
Blue=	164	Blue=	236	Blue=	251	Blue=	97	Blue=	166
W=	80	W=	96	W=	147	W=	0	W=	0
DMX VALUES 9-12		DMX VALUES 61-64		DMX VALUES 113-116		DMX VALUES 165-168		DMX VALUES 217-220	
Red=	77	Red=	238	Red=	151	Red=	175	Red=	1
Green=	255	Green=	93	Green=	138	Green=	77	Green=	100
Blue=	112	Blue=	255	Blue=	255	Blue=	173	Blue=	167
W=	77	W=	93	W=	138	W=	0	W=	0
DMX VALUES 13-16		DMX VALUES 65-68		DMX VALUES 117-120		DMX VALUES 169-172		DMX VALUES 221-224	
Red=	117	Red=	196	Red=	151	Red=	119	Red=	0
Green=	255	Green=	87	Green=	138	Green=	130	Green=	40
Blue=	83	Blue=	255	Blue=	255	Blue=	199	Blue=	86
W=	83	W=	87	W=	138	W=	0	W=	0
DMX VALUES 17-20		DMX VALUES 69-72		DMX VALUES 121-124		DMX VALUES 173-176		DMX VALUES 225-228	
Red=	160	Red=	150	Red=	138	Red=	147	Red=	209
Green=	255	Green=	90	Green=	169	Green=	164	Green=	219
Blue=	77	Blue=	255	Blue=	255	Blue=	212	Blue=	182
W=	77	W=	90	W=	138	W=	0	W=	0
DMX VALUES 21-24		DMX VALUES 73-76		DMX VALUES 125-128		DMX VALUES 177-180		DMX VALUES 229-232	
Red=	223	Red=	100	Red=	255	Red=	88	Red=	42
Green=	255	Green=	77	Green=	255	Green=	2	Green=	165
Blue=	83	Blue=	255	Blue=	255	Blue=	163	Blue=	85
W=	83	W=	77	W=	255	W=	0	W=	0
DMX VALUES 25-28		DMX VALUES 77-80		DMX VALUES 129-132		DMX VALUES 181-184		DMX VALUES 233-236	
Red=	255	Red=	77	Red=	255	Red=	0	Red=	0
Green=	243	Green=	100	Green=	206	Green=	38	Green=	46
Blue=	77	Blue=	255	Blue=	143	Blue=	86	Blue=	35
W=	77	W=	77	W=	0	W=	0	W=	0
DMX VALUES 29-32		DMX VALUES 81-84		DMX VALUES 133-136		DMX VALUES 185-188		DMX VALUES 237-240	
Red=	255	Red=	67	Red=	254	Red=	0	Red=	8
Green=	200	Green=	148	Green=	177	Green=	142	Green=	107
Blue=	74	Blue=	255	Blue=	153	Blue=	208	Blue=	222
W=	74	W=	67	W=	0	W=	0	W=	0
DMX VALUES 33-36		DMX VALUES 85-88		DMX VALUES 137-140		DMX VALUES 189-192		DMX VALUES 241-244	
Red=	255	Red=	77	Red=	254	Red=	52	Red=	107
Green=	166	Green=	195	Green=	192	Green=	148	Green=	156
Blue=	77	Blue=	255	Blue=	138	Blue=	209	Blue=	231
W=	77	W=	77	W=	0	W=	0	W=	0
DMX VALUES 37-40		DMX VALUES 89-92		DMX VALUES 141-144		DMX VALUES 193-196		DMX VALUES 245-248	
Red=	255	Red=	77	Red=	254	Red=	1	Red=	165
Green=	125	Green=	234	Green=	165	Green=	134	Green=	198
Blue=	74	Blue=	255	Blue=	98	Blue=	201	Blue=	247
W=	74	W=	77	W=	0	W=	0	W=	0
DMX VALUES 41-44		DMX VALUES 93-96		DMX VALUES 145-148		DMX VALUES 197-200		DMX VALUES 249-252	
Red=	255	Red=	158	Red=	254	Red=	0	Red=	0
Green=	97	Green=	255	Green=	121	Green=	145	Green=	0
Blue=	77	Blue=	144	Blue=	0	Blue=	212	Blue=	255
W=	74	W=	144	W=	0	W=	0	W=	0
DMX VALUES 45-48		DMX VALUES 97-100		DMX VALUES 149-152		DMX VALUES 201-204		DMX VALUES 253-255	
Red=	255	Red=	255	Red=	176	Red=	255	Red=	0
Green=	71	Green=	251	Green=	17	Green=	0	Green=	0
Blue=	77	Blue=	153	Blue=	0	Blue=	0	Blue=	0
W=	71	W=	153	W=	0	W=	0	W=	255
DMX VALUES 49-52		DMX VALUES 101-104		DMX VALUES 153-156		DMX VALUES 205-208			
Red=	255	Red=	255	Red=	96	Red=	0		
Green=	83	Green=	175	Green=	0	Green=	255		
Blue=	134	Blue=	147	Blue=	11	Blue=	0		
W=	83	W=	147	W=	0	W=	0		

PIXEL CONTROL

The fixture features pixel control in Extended DMX channel mode.
See diagram below, which illustrates the specific pixel mapping order.

STANDARD

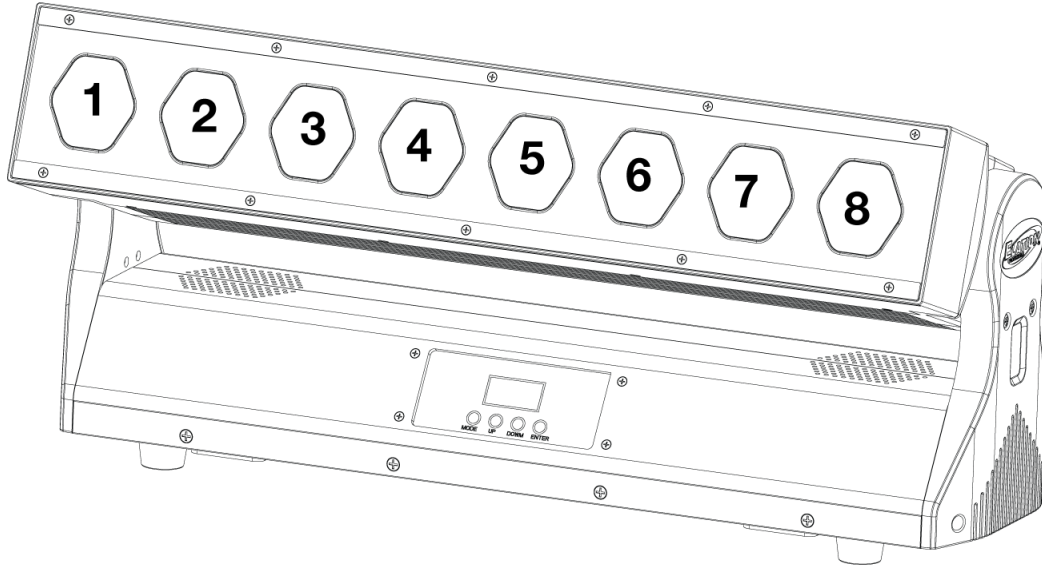

FLIP

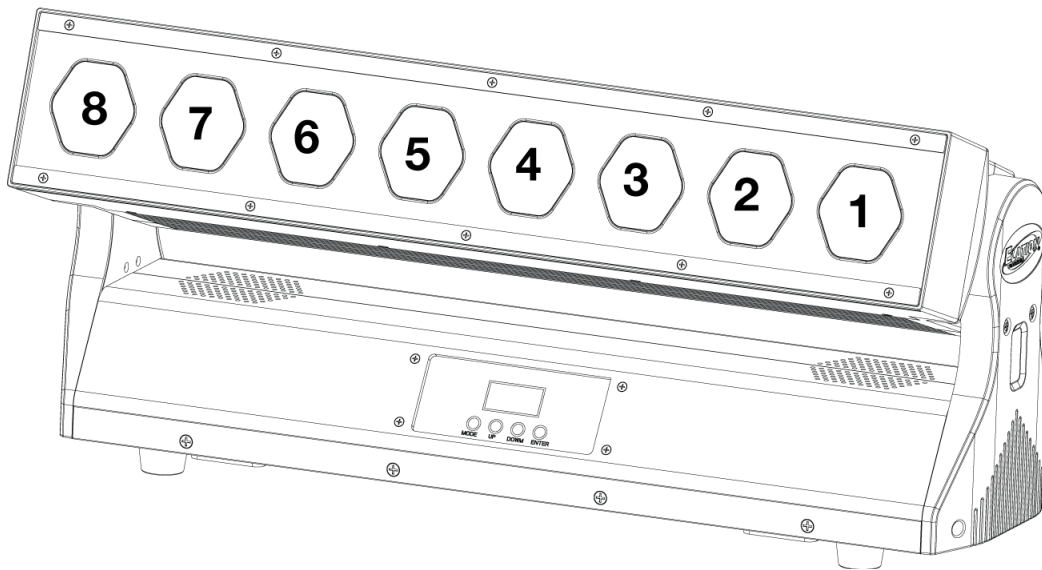

TECHNICAL SPECIFICATIONS

SOURCE

(8) 40W 4-in-1 RGBW LEDs
50,000 Hour Average LED Life*

*May vary depending on several factors including but not limited to:
Environmental Conditions, Power/Voltage, Usage Patterns (On-Off Cycling), Control, and Dimming.

PHOTOMETRIC DATA

3,000+ Total Lumens
8,702 LUX 809 FC @16.4 ft (5m) (Full ON (4° Min Zoom)
318 LUX 21 FC @16.4 ft (5m) (Full ON (37° Max Zoom)
Zoom Range 4° - 40°
Beam Angle 4.6° - 37.8°
Field Angle 7.8° - 54.4°

EFFECTS

Motorized Zoom and 220° Tilt Movement
RGBW Color Mixing and Full Pixel Control
2,700K - 7,000K Linear Color Temperature
64 Color Presets and 14 Unique Color Macros
Electronic Strobe, 16-bit Variable Dimming Curve Modes

COLOR

RGBW

CONTROL / CONNECTIONS

3 DMX Channel Modes (46 total channels)
DMX, RDM, Kling-Net, and Art-Net Protocol Support
Adjustable LED Refresh Rate (900-25,000 Hz)
Adjustable LED Gamma Brightness (2.0, 2.2, 2.4, 2.8)
4 Button Touch Control Panel
180° Reversible LCD Menu Display
8 / 16-Bit Resolution Zoom and Tilt Movement
5pin DMX In/Out
RJ45 Ethernet In/Out
Locking Power Cable Power In/Out
With Wired Digital Communication Network

SIZE / WEIGHT

Length: 21.28" (540.5mm)
Width: 7.44" (189mm)
Vertical Height: 11.46" (291mm)
Weight: 25.0 lbs (11.3 kg)

ELECTRICAL / THERMAL

AC 100-240V - 50/60Hz
359W Max Power Consumption
5°F to 113°F (-15°C to 45°C)
BTU/hr (+/- 10%) 1224.2

APPROVALS / RATINGS



Specifications and improvements in the design of this unit and this manual are subject to change without any prior written notice.

DIMENSIONAL DRAWINGS

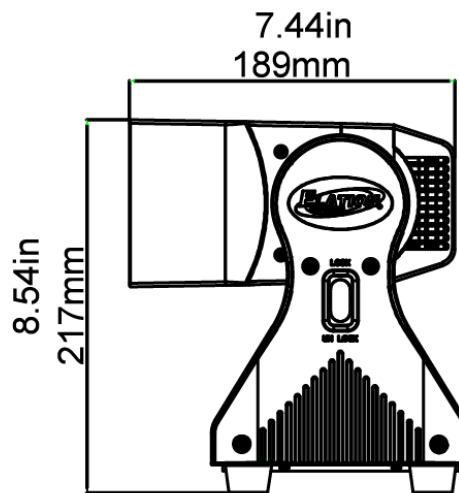
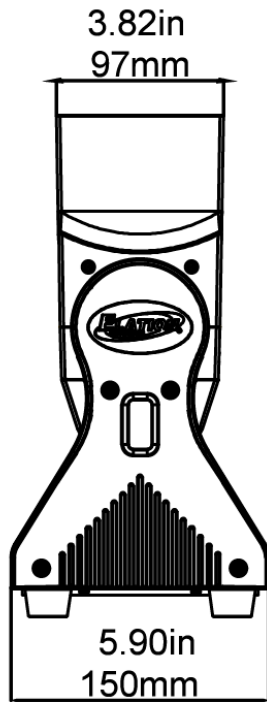
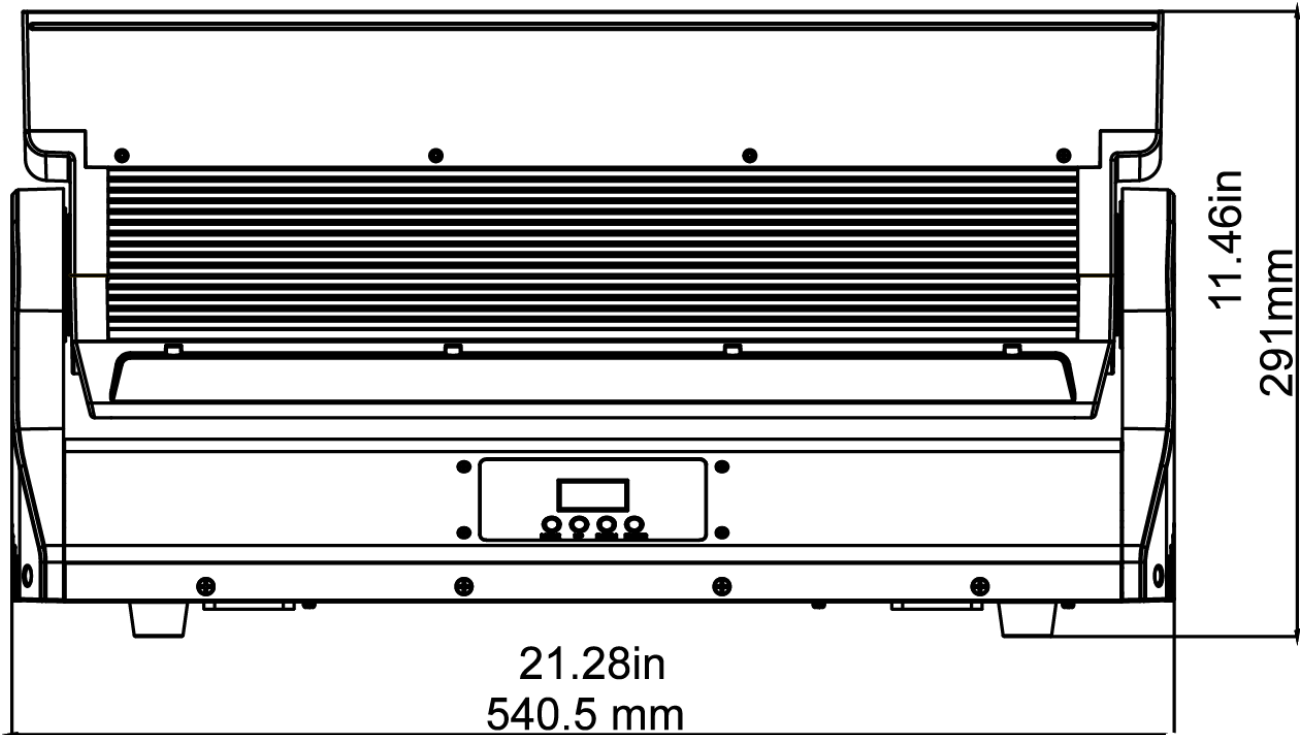

Please Note: Specifications and improvements in the design of this unit and this manual are subject to change without any prior written notice.

OPTIONAL ACCESSORIES

ORDER CODE	ITEM
DRCCL8	6-Pack Road Case for Chorus Line 8
NARROW CLAMP	Heavy Duty Wrap Around Hook Style Clamp
AC5PDMX5PRO	5 ft. (1.5m) 5pin PRO DMX Cable
PLC3	3 ft. (1m) PRO Link Cable
	Additional Cable Lengths Available

FCC STATEMENT

This device complies with Part 15 of the FCC Rules. Operation is subject to the following two conditions: (1) this device may not cause harmful interference, and (2) this device must accept any interference received, including interference that may cause undesired operation.

FCC RADIO FREQUENCY INTERFERENCE WARNINGS & INSTRUCTIONS

This product has been tested and found to comply with the limits as per Part 15 of the FCC Rules. These limits are designed to provide reasonable protection against harmful interference in a residential installation. This device uses and can radiate radio frequency energy and, if not installed and used in accordance with the included instructions, may cause harmful interference to radio communications. However, there is no guarantee that interference will not occur in a particular installation. If this device does cause harmful interference to radio or television reception, which can be determined by turning the device off and on, the user is encouraged to try to correct the interference by one or more of the following methods:

- Reorient or relocate the device.
- Increase the separation between the device and the receiver.
- Connect the device to an electrical outlet on a circuit different from which the radio receiver is connected.
- Consult the dealer or an experienced radio/TV technician for help.

Europe Energy Saving Notice

Energy Saving Matters (EuP 2009/125/EC)

Saving electric energy is a key to help protecting the environment. Please turn off all electrical products when they are not in use. To avoid power consumption in idle mode, disconnect all electrical equipment from power when not in use. Thank you



