

ELIMINATOR[®]

LIGHTING

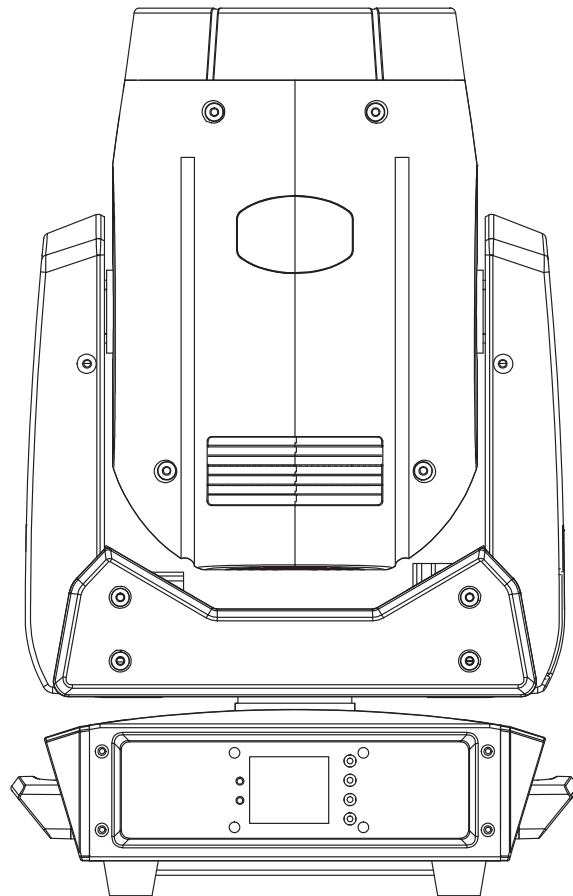

STRYKER BEAM

User Instructions

©2023 **Eliminator Lighting** all rights reserved. Information, specifications, diagrams, images, and instructions herein are subject to change without notice. Eliminator Lighting logo and identifying product names and numbers herein are trademarks of ADJ Products, LLC. Copyright protection claimed includes all forms and matters of copyrightable materials and information now allowed by statutory or judicial law or hereinafter granted. Product names used in this document may be trademarks or registered trademarks of their respective companies and are hereby acknowledged. All non-Eliminator brands and product names are trademarks or registered trademarks of their respective companies.

Eliminator Lighting and all affiliated companies hereby disclaim any and all liabilities for property, equipment, building, and electrical damages, injuries to any persons, and direct or indirect economic loss associated with the use or reliance of any information contained within this document, and/or as a result of the improper, unsafe, insufficient and negligent assembly, installation, rigging, and operation of this product.

DOCUMENT VERSION



Due to additional product features and/or enhancements, an updated version of this document may be available online.

Please check www.adj.com for the latest revision/update of this manual before beginning installation and/or programming.

Date	Document Version	Software Version	DMX Channels	Notes
02/27/2023	1.0	1.0	13/19 ch.	Initial Release
05/22/2023	1.1	N/C	No Change	Updated FCC Statement
08/23/2023	1.2	N/C	No Change	Updated Specifications

Europe Energy Saving Notice

Energy Saving Matters (EuP 2009/125/EC)

Saving electric energy is a key to help protecting the environment. Please turn off all electrical products when they are not in use. To avoid power consumption in idle mode, disconnect all electrical equipment from power when not in use. Thank you!

TABLE OF CONTENTS

Introduction	4
Limited Warranty (USA Only) Warranty Registration	5
Features	6
Safety Precautions	7
Overview	8
Installation	9
Color Wheel Gobos	13
Control Panel	14
System Menu	15
DMX Set Up	18
DMX Traits	21
Primary-Secondary Set Up	24
Maintenance Guidelines	25
Dimensional Drawings	26
Specifications	27

INTRODUCTION

Unpacking: Thank you for purchasing the Stryker Beam. Every device has been thoroughly tested and has been shipped in perfect operating condition. Carefully check the shipping carton for damage that may have occurred during shipping. If the carton appears to have been damaged, carefully inspect your fixture for any damage and be sure all accessories necessary to operate the unit have arrived intact. In the event that damage has been found or parts are missing, please contact our toll free customer support number for further instructions. Do not return this unit to your dealer without first contacting customer support.

Introduction: The Stryker Beam is a DMX-capable, LED-powered moving head fixture. It features multiple selectable DMX channel modes, pan and tilt control, 13 colors, and 11 static gobos, among other effects.

Customer Support: Contact ADJ Service for any product related service and support needs. Also visit forums.adj.com with questions, comments or suggestions.

Parts: To purchase parts online visit:

<http://parts.adj.com> (US)

<http://www.adjparts.eu> (EU)

ADJ SERVICE USA - Monday - Friday 8:00am to 4:30pm PST

Voice: 800-322-6337 | Fax: 323-582-2941 | support@adj.com

ADJ SERVICE EUROPE - Monday - Friday 08:30 to 17:00 CET

Voice: +31 45 546 85 60 | Fax: +31 45 546 85 96 | support@adj.eu

ADJ PRODUCTS LLC USA

6122 S. Eastern Ave. Los Angeles, CA. 90040

323-582-2650 | Fax 323-532-2941 | www.adj.com | info@adj.com

ADJ SUPPLY Europe B.V

Junostraat 2 6468 EW Kerkrade, The Netherlands

+31 (0)45 546 85 00 | Fax +31 45 546 85 99

www.americandj.eu | info@americandj.eu

ADJ PRODUCTS GROUP Mexico

AV Santa Ana 30 Parque Industrial Lerma, Lerma, Mexico 52000

+52 (728) 282-7070

CAUTION! This device is intended for indoor use only! Do not expose to rain or moisture!

CAUTION! There are no user serviceable parts inside this unit. Do not attempt any repairs yourself, as doing so will void your manufacturer's warranty. In the unlikely event your unit may require service, please contact ADJ Products, LLC.

Do not discard the shipping carton in the trash. Please recycle when ever possible.

LIMITED WARRANTY (USA ONLY)

1 Year Limited Warranty: The Eliminator Lighting warranty is valid for 1 year from the date of purchase. Our 1 year limited warranty covers manufacturing defects only. The serial number of your device and the place of purchase with dated valid receipt must be submitted at time of service. The Eliminator Lighting warranty does not cover items or parts prone to wear and tear: lamps, fuses, brushes and belts. Eliminator Lighting warranty is only valid within the United States.

To register your Eliminator Lighting product online, please click here to the ADJ Warranty Registration Page:
<https://www.adj.com/portal/user/register/>

WARRANTY REGISTRATION

Please fill out the enclosed warranty card to validate your purchase. All returned service items, whether under warranty or not, must be freight pre-paid and accompanied by a return authorization (R.A.) number. The R.A. number must be clearly written on the outside of the return package. A brief description of the problem as well as the R.A. number must also be written down on a piece of paper included in the shipping carton. If the unit is under warranty, you must provide a copy of your proof of purchase invoice. You may obtain an R.A. number by contacting our customer support team. All packages returned to the service department not displaying an R.A. number on the outside of the package will be returned to the shipper.

FEATURES

- 1 x 100W LED
- Multiple selectable DMX channel modes
- Pan and tilt adjustment
- 13 colors
- 11 static gobos
- Effect wheel with bi-directional rotating prisms
- Single 6-color chip
- Adjustable dimming and strobing
- LCD display

INCLUDED ITEMS

- Power Cable (x1)
- Omega Bracket (x1)

SAFETY PRECAUTIONS



PROTECTION CLASS 1 - FIXTURE MUST BE PROPERLY GROUNDED.



THERE ARE NO USER SERVICEABLE PARTS INSIDE THIS UNIT. DO NOT ATTEMPT ANY REPAIRS YOURSELF, AS DOING SO WILL VOID YOUR MANUFACTURER'S WARRANTY. DAMAGES RESULTING FROM MODIFICATIONS TO THIS FIXTURE AND/OR THE DISREGARD OF SAFETY INSTRUCTIONS AND GUIDELINES IN THIS MANUAL VOID THE MANUFACTURER'S WARRANTY AND ARE NOT SUBJECT TO ANY WARRANTY CLAIMS AND/OR REPAIRS.



INDOOR USE ONLY! DO NOT EXPOSE TO RAIN OR MOISTURE!



**NEVER LOOK DIRECTLY INTO THE LIGHT SOURCE!
RETINA INJURY RISK - MAY INDUCE BLINDNESS!
SENSITIVE PERSONS MAY SUFFER AN EPILEPTIC SHOCK!**

- **Maximum ambient operating temperature is 113° F (45° C)!**
- DO NOT TOUCH the fixture housing during operation. Disconnect the power and allow approximately 15 minutes for the fixture to cool down before servicing.
- DO NOT shake the fixture, and avoid brute force when installing and/or operating the fixture.
- DO NOT operate the fixture if the power cord has become frayed, crimped and/or damaged. If the power cord is damaged, replace immediately with a new one of the same power rating.
- DO NOT attempt to remove or break off the ground prong from the electrical cord. This prong is used to reduce the risk of electrical shock and fire in the event of an internal short.
- DO NOT attempt to operate this unit if it has been damaged in any way.
- DO NOT spill water or other liquids into or on to your unit.
- Disconnect from main power before making any type of connection.
- DO NOT block any air ventilation slots. All fan and air inlets must remain clean and never blocked. Allow approx. 20" (50cm) between fixture and other devices or a wall for proper cooling.
- Always be sure to mount this unit in an area that will allow proper ventilation. Allow about 20" (50cm) between this device and a wall.
- DO NOT remove the cover for any reason.
- When installing fixture in a suspended environment, always use mounting hardware that is no less than M10 x 25mm, and always install fixture with an appropriately rated safety cable.
- Never plug this unit in to a dimmer pack.
- During long periods of non-use, disconnect the unit's main power.
- Always mount this unit in safe and stable matter.
- Power-supply cords should be routed so that they are not likely to be walked on or pinched by items placed upon or against them, paying particular attention to the point where they exit from the unit.
- Cleaning - The fixture should be cleaned only as recommended by the manufacturer.
- Heat - The appliance should be situated away from heat sources such as radiators, heat registers, stoves, or other appliances (including amplifiers) that produce heat.
- The fixture should be serviced by qualified service personnel when:
 - A. The power-supply cord or the plug have been damaged.
 - B. Objects have fallen onto, or liquid has been spilled into, the fixture.
 - C. The fixture does not appear to operate normally or exhibits a marked change in performance.
 - D. The fixture has fallen and/or has been subjected to extreme handling.

OVERVIEW

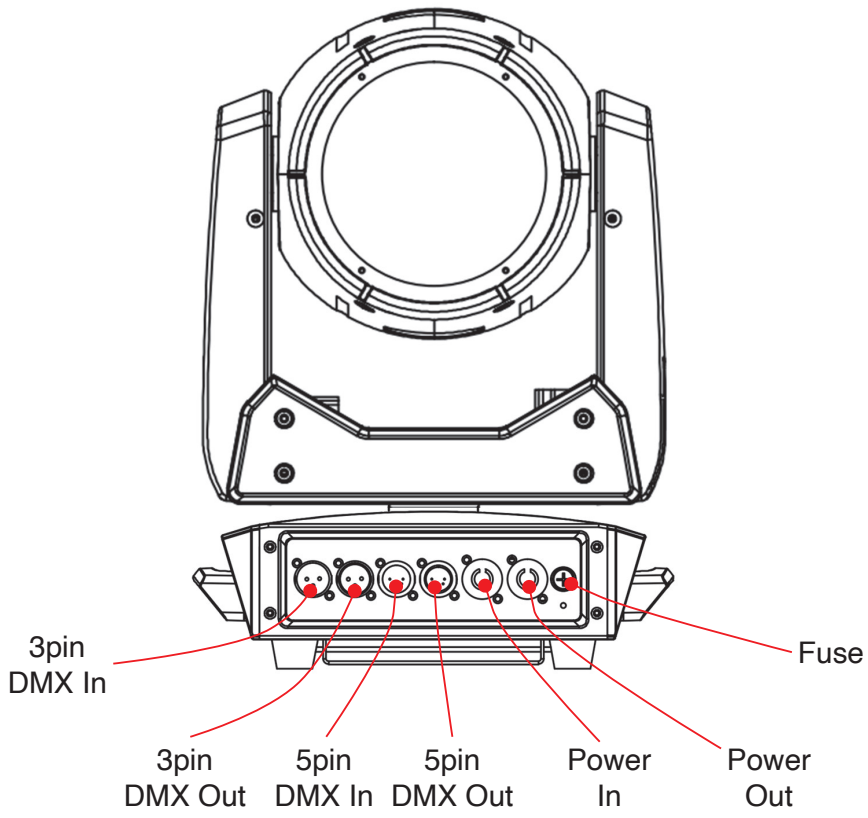
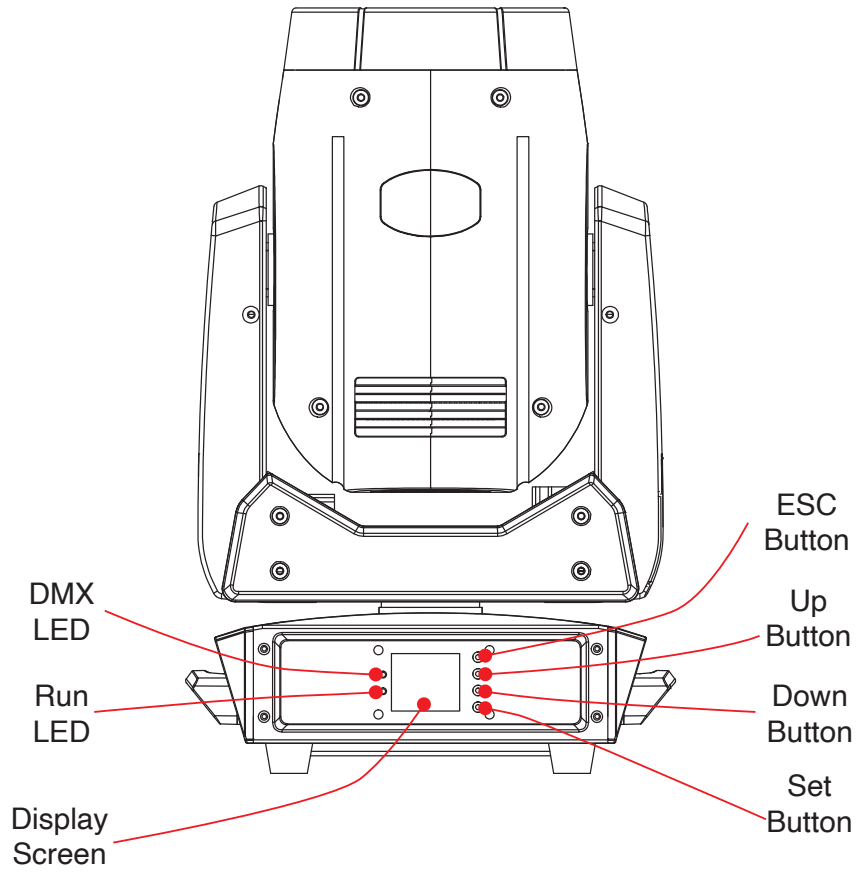

INSTALLATION



DO NOT INSTALL THE FIXTURE IF YOU ARE NOT QUALIFIED TO DO SO!

Fixture **MUST** be installed following all local, national, and country commercial electrical and construction codes and regulations.

When installing the unit, the trussing or area of installation must be able to hold at least 10 times the weight of the unit and any attached accessories without any deformation. The unit must be secured with a secondary safety attachment, e.g. an appropriately-rated safety cable.

Before rigging/mounting a single fixture to any metal truss/structure or placing the fixture(s) on any surface, a professional equipment installer **MUST** be consulted to determine if the metal truss/structure or surface is properly certified to safely hold the combined weight of the fixture(s), clamps, cables, and accessories.

Maximum ambient operating temperature is **113°F (45°C)**.

Fixture(s) should be installed away from walking paths, seating areas, or areas where unauthorized personnel might reach the fixture by hand.

NEVER stand directly below the fixture(s) when rigging, removing, or servicing.

Overhead fixture installation must always be secured with a secondary safety attachment, such as an appropriately rated safety cable that can hold at least 10 times the weight of the fixture.

Overhead mounting requires extensive experience, including calculating working load limits, knowledge of installation material being used, and periodic safety inspection of all installation material as well as the unit itself. If you lack these qualifications, do not attempt the installation yourself.

The installation should be checked by a skilled person once a year.

INSTALLATION

CLAMP MOUNTING

This fixture features attachment points for two mounting clamps on the bottom surface of the unit. Additionally, the unit also features a safety cable loop located just below the display screen (see the illustration below). When mounting the fixture to a truss or any other suspended or overhead installation, be sure to secure **TWO** appropriately rated clamps (not included) to the bracket installation points, and attach a separate **SAFETY CABLE** of the appropriate weight rating to the provided safety cable loop.

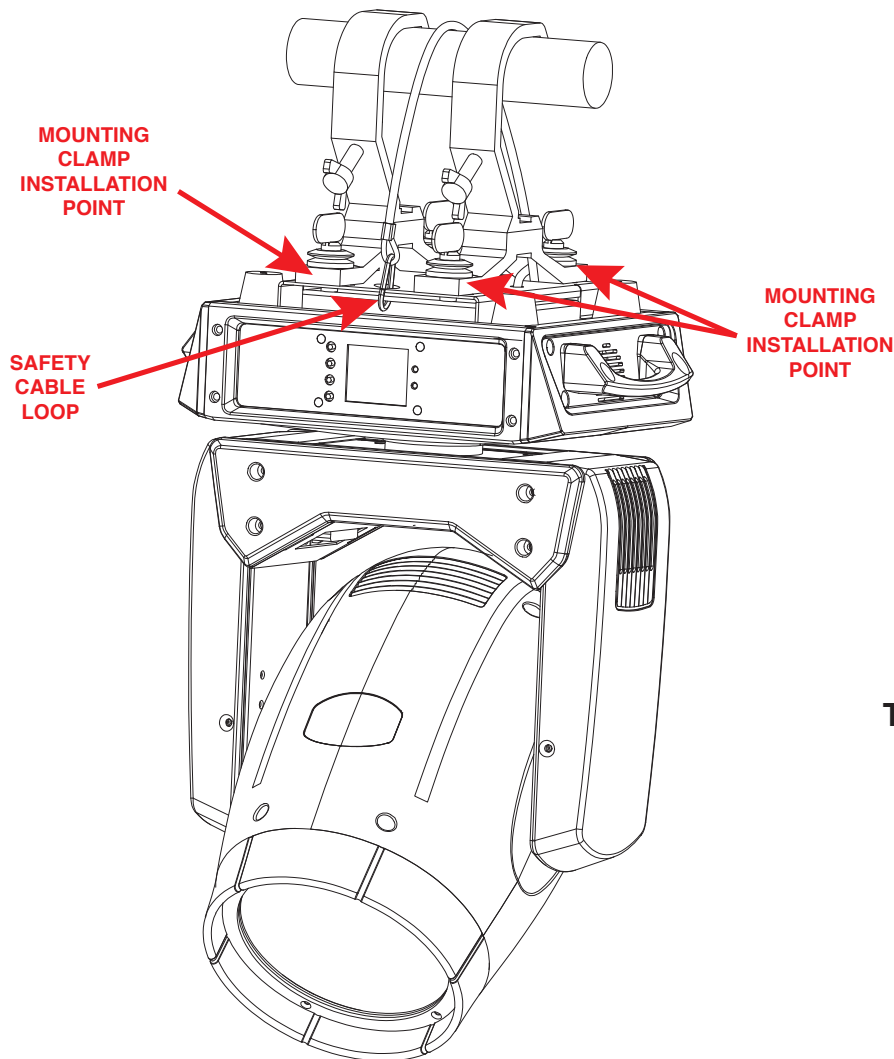

SAFETY CABLE:
ALWAYS ATTACH A SAFETY CABLE WHENEVER INSTALLING THIS FIXTURE IN A SUSPENDED ENVIRONMENT TO ENSURE THAT THE FIXTURE WILL NOT FALL IF THE CLAMP FAILS.

NOTICE: The maximum ambient operational temperature for this lighting fixture is **113° F (45° C)**. Do not place this lighting fixture in an environment where the temperatures exceed this value. This will allow the fixture to run at its best and help prolong the fixture life.

INSTALLATION

RIGGING ORIENTATIONS

Overhead rigging requires extensive experience, including calculating working load limits, installation material being used, and periodic safety inspection of all installation material and the fixture, among other skills. If you lack these qualifications, do not attempt the installation yourself. Improper installation can result in bodily injury.

The fixture is fully operational in the following positions: hanging from a horizontal truss, suspended sideways from a vertical truss, or standing upright on a flat, level surface. See the illustration below for reference.

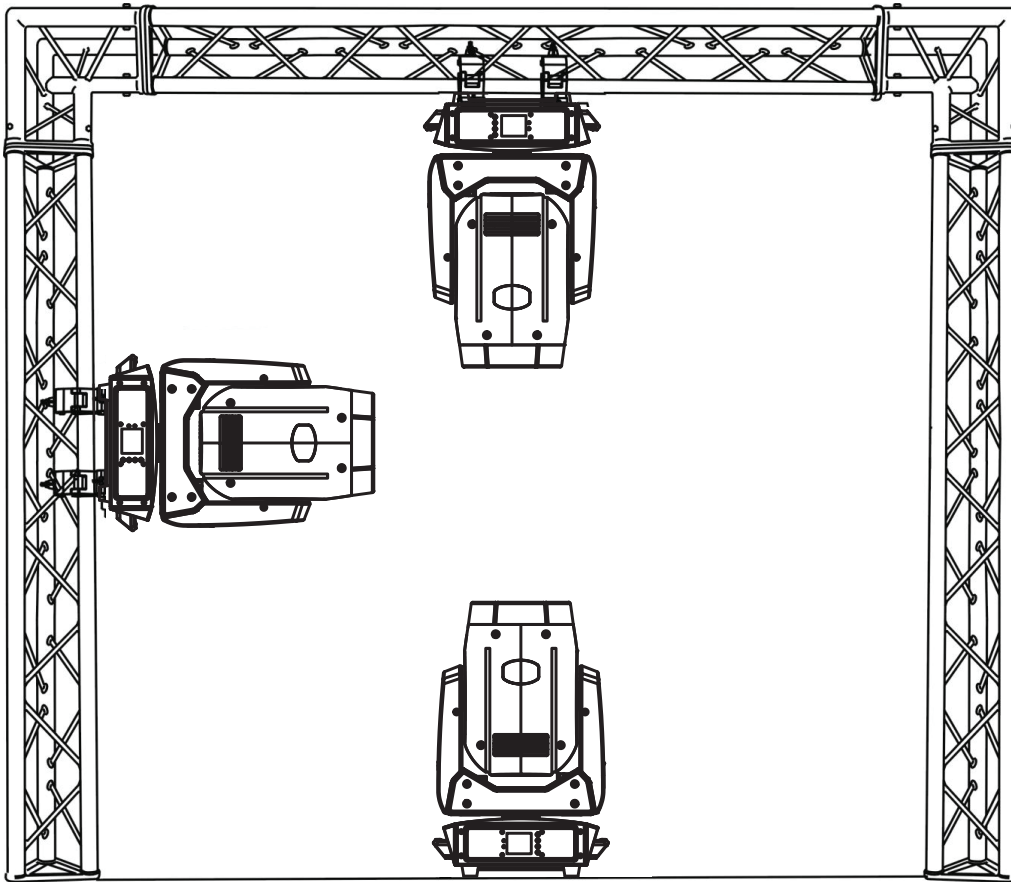

INSTALLATION

POTENTIAL INTERNAL FIXTURE DAMAGE FROM EXTERNAL SOURCES OF LIGHT BEAMS

External sources of light beams from direct sunlight, lighting and moving head fixtures, and lasers, which are focused directly towards the exterior housing and/or penetrate the front lens opening of Eliminator lighting fixtures, can cause severe internal damage including burning of optics, dichroic color filters, glass and metal gobos, prisms, animation wheels, frost filters, iris, shutters, motors, belts, wiring, discharge lamps, and LEDs.

This issue is not specific only to Eliminator lighting fixtures, but rather it is a common issue with lighting fixtures from all manufacturers. Although there is no true way to fully prevent this issue from happening, the guidelines below can reduce the risk of potential damage. Contact ADJ Service for more details.

DO NOT EXPOSE THE FIXTURE AND/OR FRONT LENS OPENING TO LIGHT BEAMS FROM DIRECT SUNLIGHT, OTHER LIGHTING OR MOVING HEAD FIXTURES, AND LASERS DURING UNPACKING, INSTALLATION, USE, AND EXTENDED IDLE TIMES OUTDOORS. DO NOT FOCUS A LIGHT BEAM FROM ONE LIGHTING FIXTURE DIRECTLY TOWARDS ANOTHER.

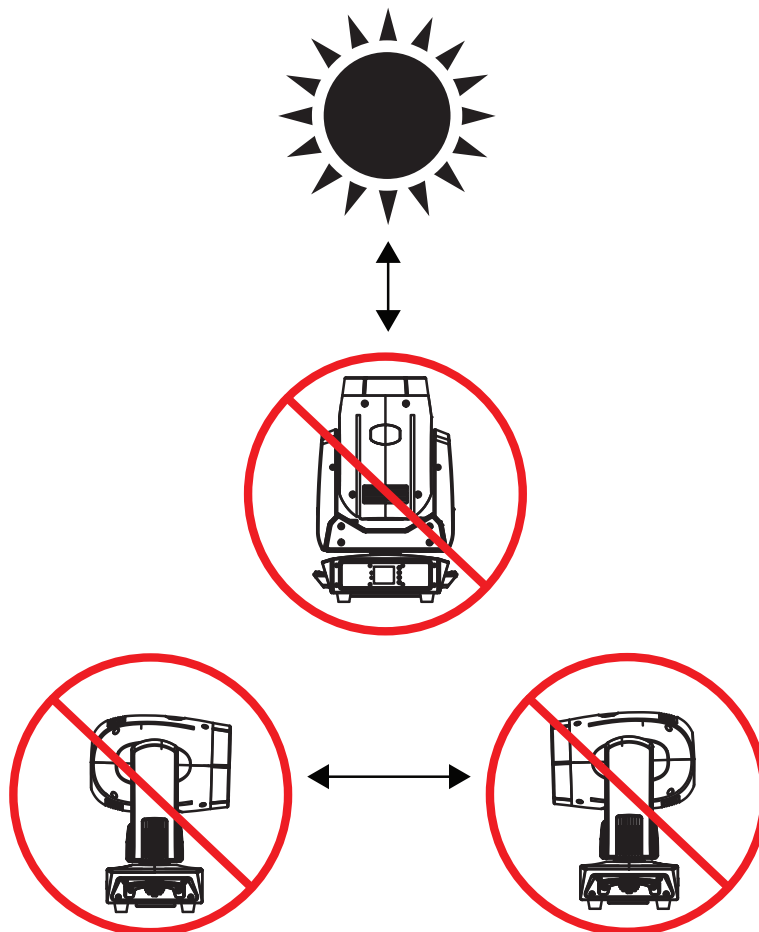

COLOR WHEEL

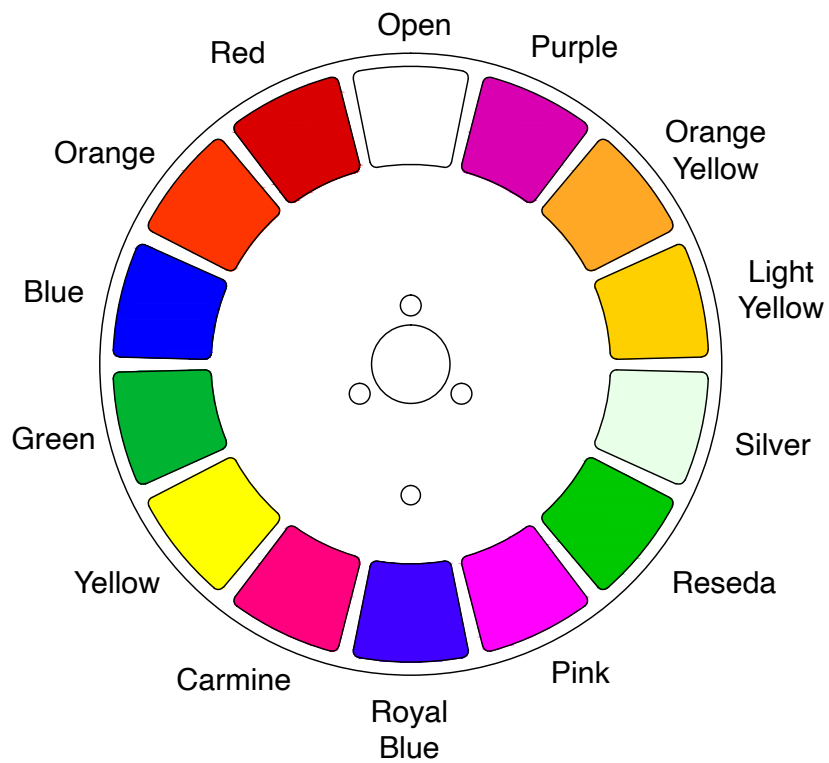

GOBOS

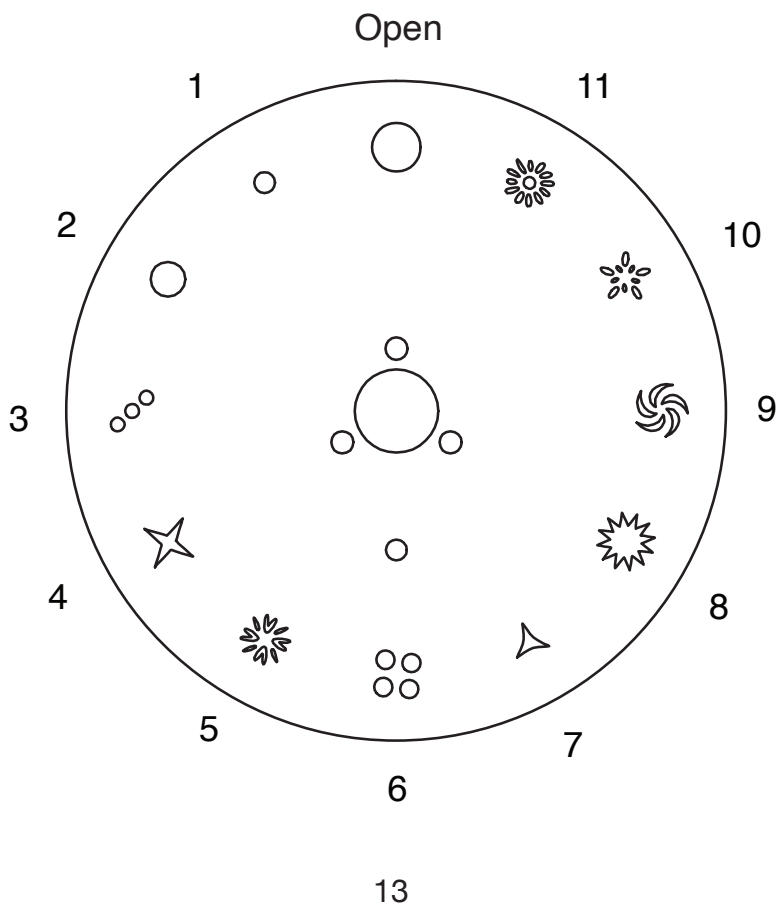

CONTROL PANEL

The Stryker Beam features a display screen with a 6-button control pad, which can be used to easily adjust any device settings.

Pressing the UP and DOWN buttons to scroll through options on the screen. Press SET to select the option currently highlighted on the screen, and enter into the Sub-Menu to adjust that setting, if applicable. Press ESC to exit without making changes.

The panel also includes two LEDs, which indicate whether the unit is in DMX mode (“DMX” LED is illuminated) or Standalone mode (“RUN” LED is illuminated).

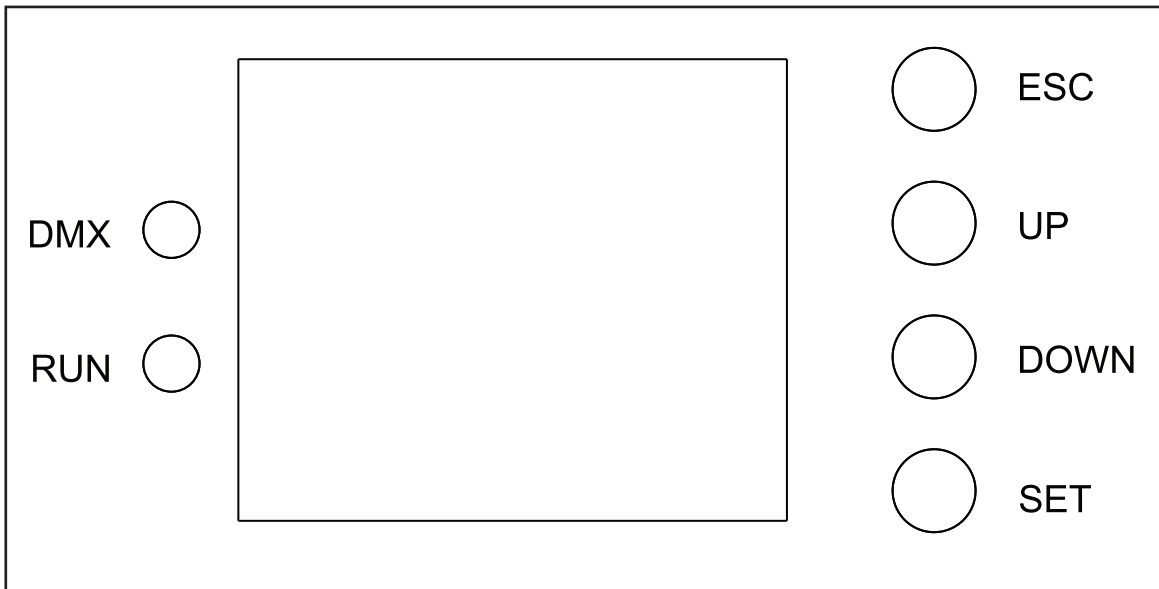

SYSTEM MENU

ADDR	001 - 512		Select DMX address
	Prev		
	Next		
	Chan	13 CH 19 CH	Select DMX channel mode
MODE	DMX Ctrl		DMX control mode
	Auto Run		Auto run mode
	Sound Ctrl		Sound active mode
	Scene Mode	Auto	Scene mode
		01 - 10	
	M/S Choose	Primary	
Auto			
Secondary			
DISP	Screen Saver	Mode 1	Black screen
		Mode 2	DMX address
		Mode 3	Model name
		Mode 4	Model name
		Off	Screen saver off
	Screen Rot	Reverse	Invert display orientation
		Forward	Standard display orientation
	DMX Indicate	Mode 1	Connected: LED On Not Connected: LED Off
		Mode 2	Connected: LED Off Not Connected: Led On
		Mode 3	Connected: LED flash Not Connected: LED Off
Screen Light	001 - 010	Screen display brightness	
SCENE	Scene Select	1 - 10	
	Scene Time	0s - 25.5s	
	Control Mode	On / Off	
	01. Pan	000 - 255	
	02. Pan Fine	000 - 255	
	03. Tilt	000 - 255	
	04. Tilt Fine	000 - 255	
	05. Color	000 - 255	
	06. Gobo	000 - 255	
	07. Strobe	000 - 255	
08. Dimmer	000 - 255		

CONTINUED ON NEXT PAGE

SYSTEM MENU

SCENE (cont'd)	09. Focus	000 - 255	
	10. Prism 1	000 - 255	
	11. Prism 1 R	000 - 255	
	12. Prism 2	000 - 255	
	13. Prism 2 R	000 - 255	
	14. Frost	000 - 255	
	15. 7 Color	000 - 255	
	16. Function	000 - 255	
	17. Mode	000 - 255	
	18. PT Speed	000 - 255	
	19. Reset	000 - 255	
ADVA	Pan Invert	On / Off	
	Tilt Invert	On / Off	
	P/T Rectify	On / Off	Returns pan/tilt to previous setting in the event of accidental strike
	Pan Offset	004 - 150	
	Tilt Offset	004 - 048	
	Data Hold	On / Off	Holds last DMX setting received if signal is lost
	Scene Time	001 - 255	
	Reset	Yes / No	Power reset: powers fixture off then powers it back on
	Factory Setting	Yes / No	Return unit to factory default settings

CONTINUED ON NEXT PAGE

SYSTEM MENU

STAT	Stepper Info	Pan	xxx	
		Tilt	xxx	
		Pan OP	xx	
		Tilt OP	xx	
		01 Pan	xxx	
		02 Tilt	xxx	
		03 Gobo1	xxx	
		04 Color1	xxx	
		05 Prism1	xxx	
		06 Prism2	xxx	
		07 Prism Rot1	xxx	
		08 Prism Rot2	xxx	
		09 Focus1	xxx	
		10 Frost	xxx	
11 MT1	xxx	Rainbow mirror motor		
STAT (cont'd)	Error Logging			Display error log
	Fixture Status	Communication	xxx%	
		Error Cnt	x	
		Light Temp	xx F / xx C	
		Panel Temp	xx F / xx C	
		Sensor1 Temp	xx F / xx C	
		Sensor2 Temp	xx F / xx C	
	Version	x.x.x		
	Light Time	xxx:xx	Time since unit was last powered on	
	Total Time	xxx:xx	Total lifetime run time	
Serial Number				

DMX SET UP

DMX-512: DMX is short for Digital Multiplex. This is a universal protocol used as a form of communication between intelligent fixtures and controllers. A DMX controller sends DMX data instructions from the controller to the fixture. DMX data is sent as serial data that travels from fixture to fixture via the DATA “IN” and DATA “OUT” XLR terminals located on all DMX fixtures (most controllers only have a DATA “OUT” terminal).

DMX Linking: DMX is a language allowing all makes and models of different manufacturers to be linked together and operate from a single controller, as long as all fixtures and the controller are DMX compliant. To ensure proper DMX data transmission, try to use the shortest cable path possible when linking several DMX fixtures. The order in which fixtures are connected in a DMX line does not influence the DMX addressing. For example, a fixture assigned a DMX address of 1 may be placed anywhere in a DMX line: at the beginning, at the end, or anywhere in the middle. When a fixture is assigned a DMX address of 1, the DMX controller knows to send DATA assigned to address 1 to that unit, no matter where it is located in the DMX chain.

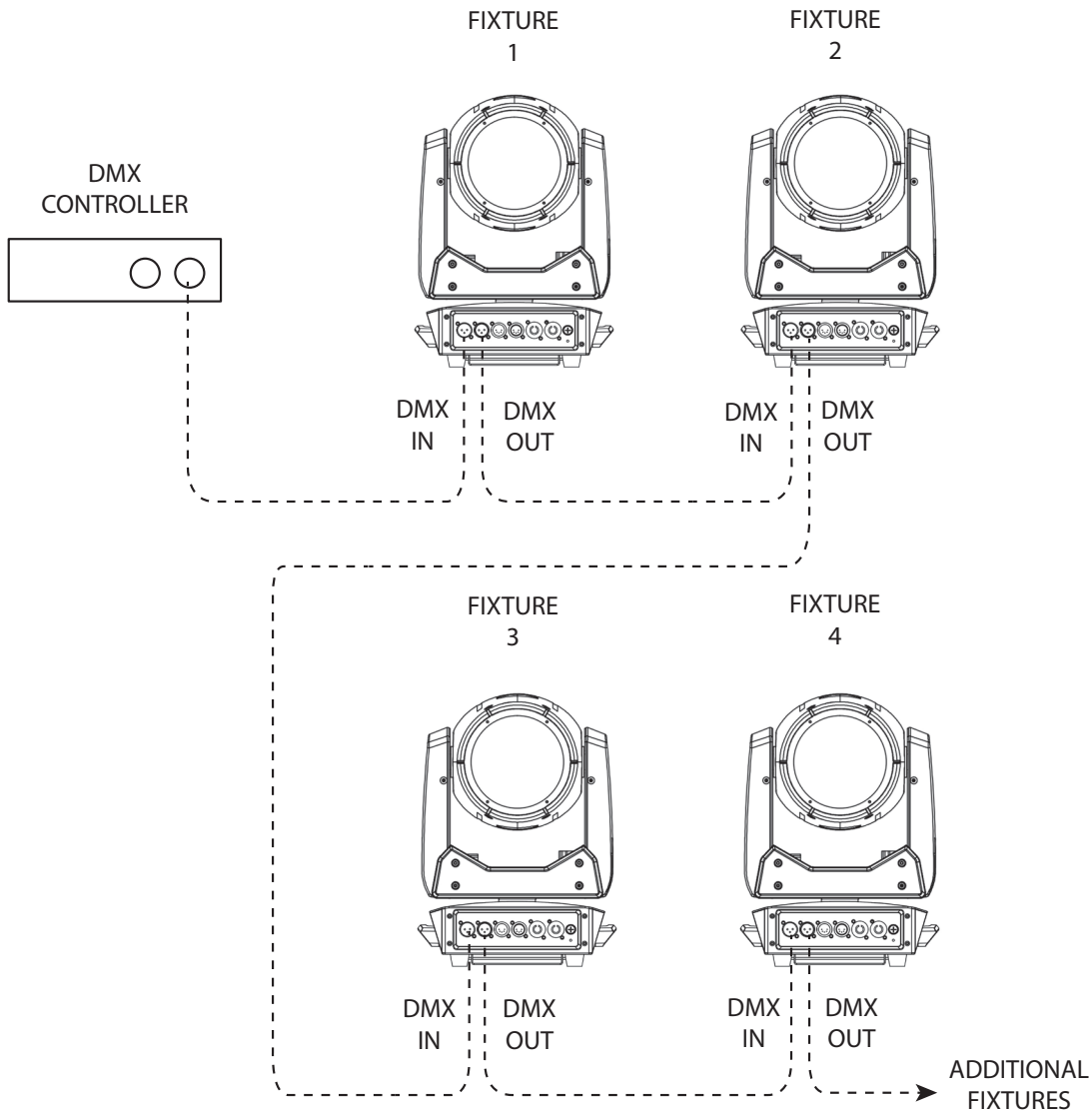

Note: The diagram above depicts DMX linking via the 3-pin DMX ports, but the units can also be linked via the 5-pin DMX ports. However, all linkages must be made using the same set of ports: all 3-pin or all 5-pin.

DMX SET UP

Data Cable (DMX Cable) Requirements (For DMX Operation): This unit can be controlled via DMX-512 protocol. The DMX address is set on the rear panel of the unit. Your unit and your DMX controller require a standard 3-pin or 5-pin XLR connector for data input and data output. We recommend Accu-Cable DMX cables. If you are making your own cables, be sure to use standard 110-120 Ohm shielded cable (This cable may be purchased at almost all pro lighting stores). Your cables should be made with a male XLR connector at one end and a female XLR connector at the other. Also remember that DMX cable must be daisy chained and cannot be split.

Notice: Be sure to follow the illustration below when making your own cables. Do not use the ground lug on the XLR connector. Do not connect the cable's shield conductor to the ground lug or allow the shield conductor to come in contact with the XLR's outer casing. Grounding the shield could cause a short circuit and erratic behavior.

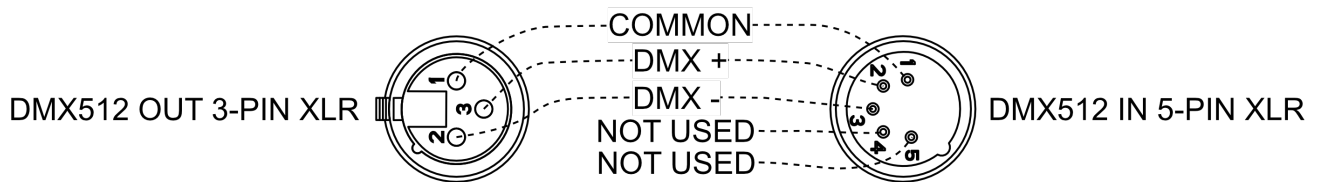

Special Note: Line Termination. When longer runs of cable are used, you may need to use a terminator on the last unit to avoid erratic behavior. A terminator is a 110-120 ohm 1/4 watt resistor which is connected between pins 2 and 3 of a male XLR connector (DATA + and DATA -). This unit is inserted in the female XLR connector of the last unit in your daisy chain to terminate the line. Using a cable terminator (ADJ part number Z-DMX/T) will reduce the risk of erratic behavior.

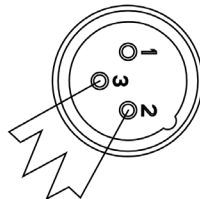
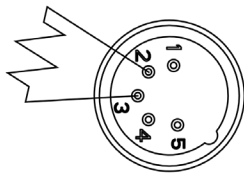

A DMX512 terminator reduces signal errors, avoiding most signal reflection interference. Connect PIN 2 (DMX-) and PIN 3 (DMX+) of the last fixture in series with a 120 Ohm, 1/4 W Resistor to terminate the DMX512.

DMX SET UP

DMX ADDRESSING.

All fixtures should be given a DMX starting address when using a DMX controller, so the correct fixture responds to the correct control signal. This digital starting address is the channel number from which the fixture starts to “listen” to the digital control signal sent out from the DMX controller. The assignment of this starting DMX address is achieved by setting the correct DMX address on the digital control display on the fixture.

You can set the same starting address for all fixtures or a group of fixtures, or set different addresses for each individual fixture. Setting all fixtures to the same DMX address will cause all fixtures to react in the same way. In other words, changing the settings of one channel will affect all the fixtures simultaneously.

If you set each fixture to a different DMX address, each unit will start to “listen” to the channel number you have set, based on the quantity of DMX channels of each fixture. That means changing the settings of one channel will only affect the selected fixture.

For example, when operating this unit in 13-channel mode, you should set the starting DMX address of the first unit to 1, the second unit to 14 (1 + 13), the third unit to 27 (1 + 13 + 13), and so on. See the chart below for more details.

CHANNEL MODE	UNIT 1 ADDRESS	UNIT 2 ADDRESS	UNIT 3 ADDRESS	UNIT 4 ADDRESS
13 Ch	1	14	27	40
19 Ch	1	20	39	58

DMX TRAITS

CHANNEL		DMX VALUES	FUNCTION
13Ch	19Ch		
1	1	000 - 255	<i>Pan</i> , 0 - 540
	2	000 - 255	<i>Pan Fine</i>
2	3	000 - 255	<i>Tilt</i> , 0 - 225
	4	000 - 255	<i>Tilt Fine</i>
3	5		<i>Color</i>
		000 - 004	White
		005 - 009	White + Red
		010 - 014	Red
		015 - 019	Red + Orange
		020 - 024	Orange
		025 - 029	Orange + Blue
		030 - 034	Blue
		035 - 039	Blue + Green
		040 - 044	Green
		045 - 049	Green + Yellow
		050 - 054	Yellow
		055 - 059	Yellow + Carmine
		060 - 064	Carmine
		065 - 069	Carmine + Royal Blue
		070 - 074	Royal Blue
		075 - 079	Royal Blue + Pink
		080 - 084	Pink
		085 - 089	Pink + Reseda
		090 - 094	Reseda
		095 - 099	Reseda + Silver
		100 - 104	Silver
		105 - 109	Silver + Light Yellow
		110 - 114	Light Yellow
		115 - 119	Light Yellow + Orange Yellow
		120 - 124	Orange Yellow
		125 - 129	Orange Yellow + Purple
130 - 134	Purple		
135 - 139	Purple + White		
140 - 149	White		
150 - 199	Clockwise Rotation (fast to slow)		
200 - 205	Stop		
206 - 255	Counter Clockwise Rotation (slow to fast)		

CONTINUED ON NEXT PAGE

DMX TRAITS

CHANNEL		DMX VALUES	FUNCTION
13Ch	19Ch		
4	6		Gobo
		000 - 009	Open
		010 - 019	Gobo1
		020 - 029	Gobo2
		030 - 039	Gobo3
		040 - 049	Gobo4
		050 - 059	Gobo5
		060 - 069	Gobo6
		070 - 079	Gobo7
		080 - 089	Gobo8
		090 - 099	Gobo9
		100 - 109	Gobo10
		110 - 119	Gobo11
		120 - 127	Gobo1 Shake, slow to fast
		128 - 135	Gobo2 Shake, slow to fast
		136 - 143	Gobo3 Shake, slow to fast
		144 - 151	Gobo4 Shake, slow to fast
		152 - 159	Gobo5 Shake, slow to fast
		160 - 167	Gobo6 Shake, slow to fast
		168 - 175	Gobo7 Shake, slow to fast
		176 - 183	Gobo8 Shake, slow to fast
		184 - 191	Gobo9 Shake, slow to fast
		192 - 199	Gobo10 Shake, slow to fast
200 - 207	Gobo11 Shake, slow to fast		
208 - 230	Clockwise Rotation, fast to slow		
231 - 232	Stop		
233 - 255	Counter Clockwise Rotation, slow to fast		
5	7		Shutter
		000 - 003	Off
		004 - 127	Strobe, slow to fast
		128 - 191	Pulse Strobe, slow to fast
		192 - 251	Random Strobe, slow to fast
		252 - 255	Open
6	8	000 - 255	Dimmer , 0% to 100%
7	9	000 - 255	Focus , far to near
CONTINUED ON NEXT PAGE			

DMX TRAITS

CHANNEL		DMX VALUES	FUNCTION
13Ch	19Ch		
			<i>Prism 1</i>
	10	000 - 127	Off
		128 - 255	On
			<i>Prism 1 Rotation</i>
	11	000 - 063	Prism Index, 0° - 400°
		064 - 126	Clockwise Rotation, fast to slow
		127 - 128	Stop
		129 - 191	Counter Clockwise Rotation, slow to fast
		192 - 255	Bi-directional Rotation, slow to fast
			<i>Prism 2</i>
	12	000 - 127	Off
		128 - 255	On
			<i>Prism 2 Rotation</i>
	13	000 - 063	Prism Index, 0° - 400°
		064 - 126	Clockwise Rotation, fast to slow
		127 - 128	Stop
		129 - 191	Counter Clockwise Rotation, slow to fast
		192 - 255	Bi-directional Rotation, slow to fast
			<i>Frost</i>
8	14	000 - 127	Off
		128 - 255	On
			<i>7 Color</i>
9	15	000	Off
		001 - 255	On
			<i>Effect Auto</i>
10	16	000 - 127	Off
		128 - 255	Auto Run On
			<i>Pan/Tilt Auto</i>
11	17	000 - 127	Off
		128 - 255	Auto Run On
12	18	000 - 255	<i>Pan/Tilt Speed</i> , fast to slow
			<i>Reset</i>
13	19	000 - 021	Off
		022 - 025	No function
		026 - 076	Reset Effect (hold 3s)
		077 - 128	Reset Pan/Tilt Motor (hold 3s)
		129 - 255	Reset All (hold 3s)

PRIMARY-SECONDARY SET UP

This function allows you to link units together to run in a Primary-Secondary set-up, in which one unit will act as the controlling unit and the others will react to the controlling unit's built-in programs. Any unit can be configured to act as a Primary or as a Secondary, but only one unit in a given system can be programmed to act as the Primary.

Primary-Secondary Connections and Settings:

1. Daisy chain your units via the XLR connectors on the rear panels of each unit. Use standard XLR data cables to link your units together. Remember that the male XLR connector is the input and the female XLR connector is the output. The first unit in the chain (primary) will use the female XLR connector only. The last unit in the chain will use the male XLR connector only.
2. Use the display screen and control panel to navigate to the "Primary / Secondary" setting in the main menu. Select this setting using the ENTER button, and use the arrows to toggle between "Primary", "Secondary1", and "Secondary2". Press ENTER to confirm your selection.
3. Repeat Step 2 for each unit in the system. Make sure that only one unit is designated as the Primary, while all other units are designated as Secondaries.
4. The secondary units will act in conjunction with the primary unit. Note that secondary units set to the "Secondary1" setting will follow the motions of the primary, while those set to the "Secondary2" setting will move in contrast to the primary.

MAINTENANCE GUIDELINES



DISCONNECT POWER BEFORE PERFORMING ANY MAINTENANCE!

CLEANING

Frequent cleaning is recommended to ensure proper function, optimized light output, and an extended life. The frequency of cleaning depends on the environment in which the fixture operates: damp, smoky, or particularly dirty environments can cause greater accumulation of dirt on the fixture's optics. Clean the external lens surface regularly with a soft cloth to avoid dirt/debris accumulation.

NEVER use alcohol, solvents, or ammonia-based cleaners.

MAINTENANCE

Regular inspections are recommended to ensure proper function and extended life. There are no user serviceable parts inside this fixture. Please refer all other service issues to an authorized ADJ or Eliminator service technician. Should you need any spare parts, please order genuine parts from your local ADJ/Eliminator dealer.

Please refer to the following points during routine inspections:

- A. A detailed electrical check by an approved electrical engineer every three months, to make sure the circuit contacts are in good condition and prevent overheating.
- B. Be sure all screws and fasteners are securely tightened at all times. Loose screws may fall out during normal operation, resulting in damage or injury as larger parts could fall.
- C. Check for any deformations on the housing, color lenses, rigging hardware, and rigging points (ceiling, suspension, trussing). Deformations in the housing could allow for dust to enter into the fixture. Damaged rigging points or unsecured rigging could cause the fixture to fall and seriously injure a person(s).
- D. Electric power supply cables must not show any damage, material fatigue, or sediments.

NEVER remove the ground prong from the power cable.

SOFTWARE UPDATES

Please contact ADJ service for assistance with updating your device's software.

DIMENSIONAL DRAWINGS

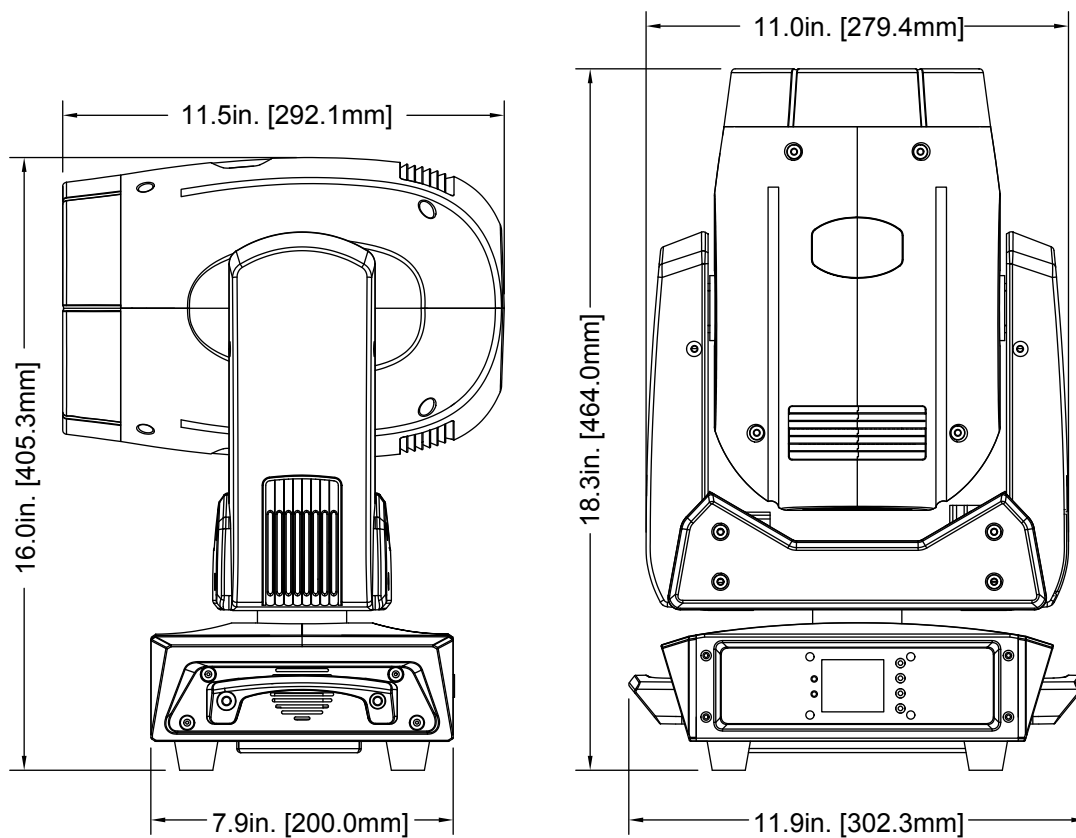

Drawings not shown to scale.

SPECIFICATIONS

LIGHT SOURCE:

- 100W LED Engine
- 6-Degree Beam Angle

FEATURES:

- Full color function display with 4 buttons
- Fast, precise, pan & tilt movements
- Primary / Secondary stand-alone mode
- Motorized Focus
- Frost Filter (50-Degree Wash Effect)

COLOR WHEEL:

- 13 colors + open
- Separate 6-Color flag for multi-color effects

GOBO WHEEL:

- Metal wheel with 11 GOBOS + open (2 are beam reducers)
- GOBO Shake Effect

PRISM WHEEL:

- 8-facet rotating circular prism
- 16-facet rotating circular prism
- Prism layering

CONTROL:

- 2 DMX channel modes: 6 & 19 channels
- Protocols: DMX-512, RDM, Auto and Primary/Secondary control modes
- Electronic Dimmer: 0- 100 %
- Variable Strobe: 0-20HZ
- With Wired Digital Communication Network

CONNECTIONS:

- DMX Data In/Out: 3-pin & 5-pin connections
- Power In: Blue Locking indoor power connection
- Power Out: White Locking indoor power connection

PAN/TILT:

- Pan/Tilt: 540-degrees / 270-degrees
- 16-bit Fine Pan
- 16-bit Fine Tilt

ELECTRICAL:

- Multi-voltage operation: AC 100-24V, 50/60Hz
- Maximum Power Consumption: 150W
- Power daisy chain: 2 units @120V, 3 units @230V

DIMENSIONS & WEIGHT:

- Dimensions (LxWxH): 11.5" x 11.9" x 18.3" / 292.1x302.3x464.0mm
- Weight: 29 lbs. / 12.8 kg.

ROAD CASES (SOLD SEPERATELY)::

- Two (2) Stryker Beam fit inside the ADJ DRC MH road case
- Four (4) Stryker Beam fit inside the ADJ QRC HM road case

WHAT'S INCLUDED:

- Locking power cord
- Omega bracket

FCC INFORMATION

FCC STATEMENT

This device complies with Part 15 of the FCC Rules. Operation is subject to the following two conditions: (1) this device may not cause harmful interference, and (2) this device must accept any interference received, including interference that may cause undesired operation.

FCC RADIO FREQUENCY INTERFERENCE WARNINGS & INSTRUCTIONS

Please note that changes or modifications of this product is not expressly approved by the party responsible for compliance could void the user's authority to operate the equipment. This product has been tested and found to comply with the limits as per Part 15 of the FCC Rules. These limits are designed to provide reasonable protection against harmful interference in a residential installation. This device uses and can radiate radio frequency energy and, if not installed and used in accordance with the included instructions, may cause harmful interference to radio communications. However, there is no guarantee that interference will not occur in a particular installation. If this device does cause harmful interference to radio or television reception, which can be determined by turning the device off and on, the user is encouraged to try to correct the interference by one or more of the following methods:

- Reorient or relocate the device.
- Increase the separation between the device and the receiver.
- Connect the device to an electrical outlet on a circuit different from which the radio receiver is connected.
- Consult the dealer or an experienced radio/TV technician for help.

Energy Saving Matters (EuP 2009/125/EC)

Saving electric energy is a key to help protecting the environment. Please turn off all electrical products when they are not in use. To avoid power consumption in idle mode, disconnect all electrical equipment from power when not in use. Thank you!



